

GC20665L14D3T4

INSTRUCTION BOOK / PARTSLIST / AC SERVO SYSTEM SERVICE MANUAL



DIRECT DRIVE 1 - AND 2-NEEDLE COMPOUND FEED
LOCKSTITCH SEWING MACHINE

TYPICAL

CONTENTS

Operation Instruction

1. Brief introduction.....	1
2. Main specifications.....	1
3. Machine installation	1
4. Installing the air filter	2
5. Setting the machine ID	2
6. Adjusting the start position	3
7. Lubrication	4
8. Adjusting the oil amount of hook	5
9. Setting the needle	5
10. Function of reverse sewing switch	6
11. Function of manual switch	6
12. Threading the bobbin	7
13. Installing the thread tension for bobbin thread winder.....	7
14. Winding bobbin thread	7
15. Threading the needle thread.....	8
16. Stitch length	8
17. Thread tension	8
18. Adjusting thread take-up spring.....	9
19. Presser foot lift.....	9
20. Pressure of presser foot.....	9
21. Adjusting needle guard plate	9
22. Reset of safety clutch	10
23. Adjusting hook thread opener	10
24. Timing between needle and rotating hook.....	10
25. Alternating lift amount of presser feet	11
26. Setting the knee switch	11
27. Adjusting the cutter	11
28. Stop position.....	12
29. Pedal operation and standing operation.....	12
30. Settings for different speeds	13

Parts Manual

1. Casting mechanism.....	14-17
2. Arm shaft & thread take-up mechanism.....	18-21
3. Needle bar rocking frame mechanism.....	22-23
4. Upper feed mechanism.....	24-27
5. Lower feed, reverse and feed regulating.....	28-31
6. Lower shaft and rotating hook.....	32-33
7. Thread tension components.....	34
8. Bobbin winder & thread nipper components.....	35
9. Thread trimming mechanism.....	36-39
10.Auto-reverse feed mechanism.....	40-41
11.Auto-lifer mechanism.....	42
12.Climbing device mechanism.....	43
13.Lubrication components.....	44-47
14. Accessories.....	48-49

Operation Instruction

1. Brief introduction

This compound feed sewing machine is designed with unique feed mechanisms, which make sewing of uneven and thick materials easily. Smooth, uniform and neat stitches are promised. The machine runs with high speed and low noise thanks for its' vertical-axis rotating hook, sliding lever take-up and synchronized belt driven mechanisms.

Driven by direct drive motor, built-in bobbin winder with assistant, integrated led sewing light, reverse stitching button and electric handwheel.

It is designed for sewing of car seats, sofas, leather bags and tents industry.

3. Machine installation (Fig.1)

1. Setting of hinges and cushions of machine head
Fix hinges ① and rubber cushions ② into the working table by nails ③, inert the felt ④.

2. Setting of oil pan
Fix oil pan ④ under the working table by six wooden screws as per illustration.

3. connect the oil pipe ⑦ from pump ⑥ with nozzle⑧ of oil pan.

2. Main specifications

Applications	Medium & heavy weight materials
Max sewing speed	2500 s.p.m
Max stitch length	9mm
Needle bar stroke	36mm
Needle	DP × 17(Nm125~Nm180) 23#
Lubrication	Oil wick (Rotating hook self oiled)
Rotating hook	Self-oiled big rotating hook
Presser foot lift height	9mm by hand, 16mm by knee/lifter
Motor power	Direct drive AC Servo motor

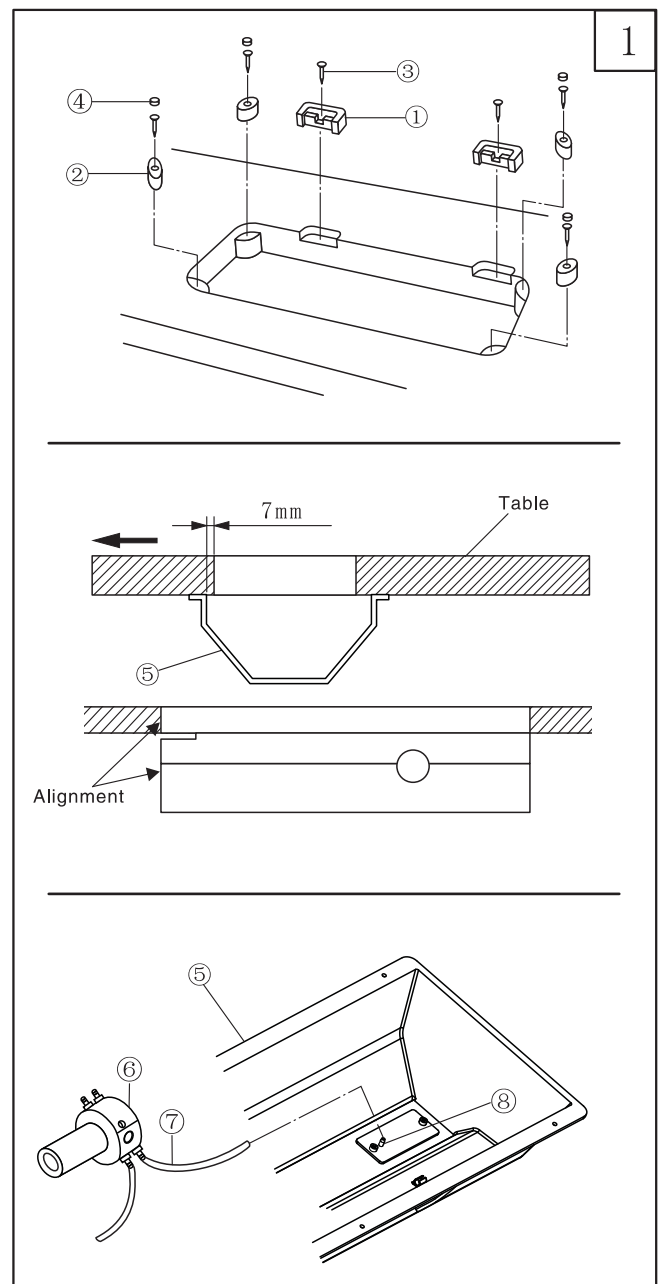

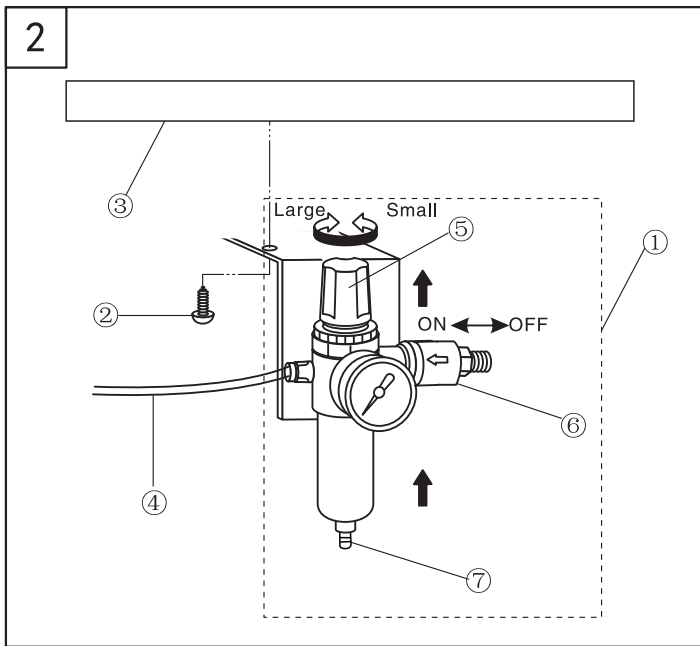

4. Installing the air filter (Fig.2)

1. Install the air filter ① under the table ③ by screw ②.
 2. Connect the air pipe ④ as fig 2 shown.
 3. Pull up nut ⑤ of air filter ①, then turn to adjust the pressure
 4. Restore nut ⑤ after adjustment.
- Note: Pneumatic pressure of the compressed air should be set to 0.55Mpa before use. If need to release the air, please close the valve ⑥ first, then push the bottom ⑦.

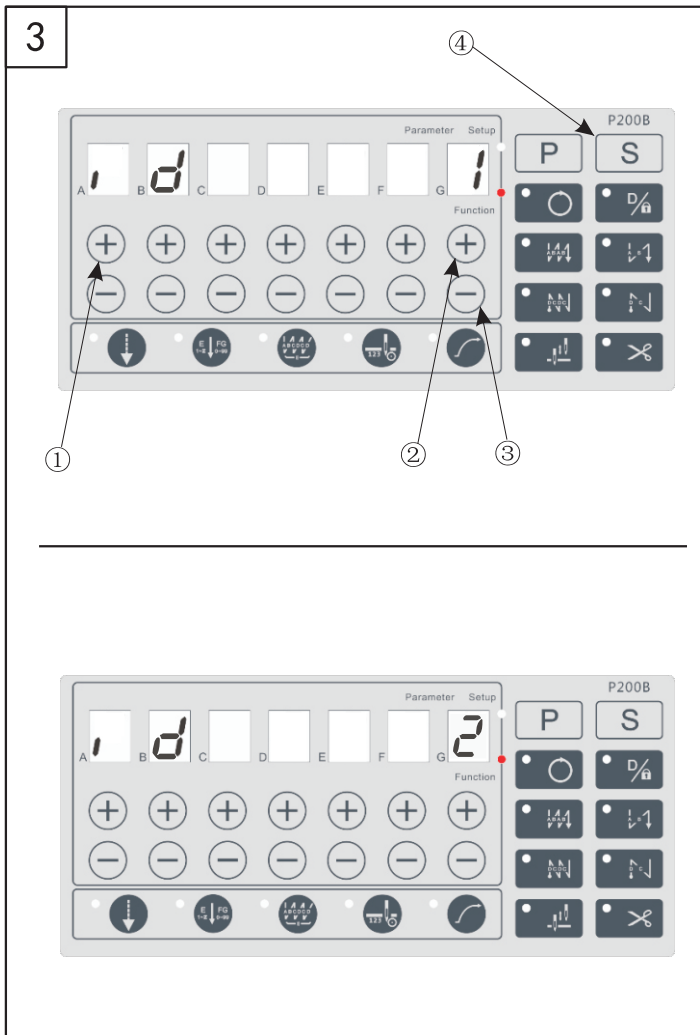

5. Setting the machine ID (Fig.3)

- NOTE; 1. When start to use, please set the machine ID first
 2 For control system YSC-8361 only

1. Press the key "+" ①, and power on, the operation panel will display "ID XX", XX is the default machine ID.
2. Adjust the keys "+2/-" ② to number "2", then press key "S" ④ to save
3. Restart the system.

ID	MODEL	MAX SPEED (sti/min)
2	GC20665L14D3T4	2500

6. Adjusting the start position (Fig.4)

NOTE:

1. After trimming, if the mark ③ over deviate from the mark ④, please adjust the system start position.
2. Before adjustment, please be sure the machine ID

1. Press the key "O" ① and power on
2. Turn the handwheel, the degree will be displayed on the panel
3. Make sure the thread take up lever is at its highest position, and mark ③ aims at mark ④, this is start position
4. Press the key "S" ② and the panel will display zero, then restart the system.

4

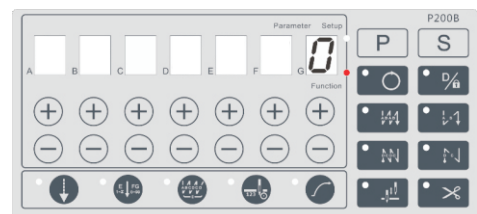
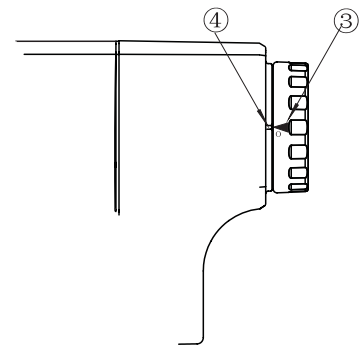
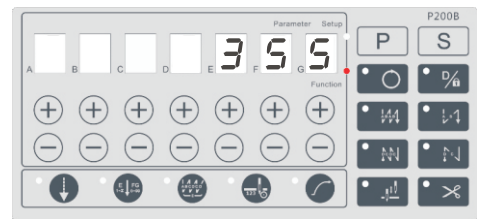
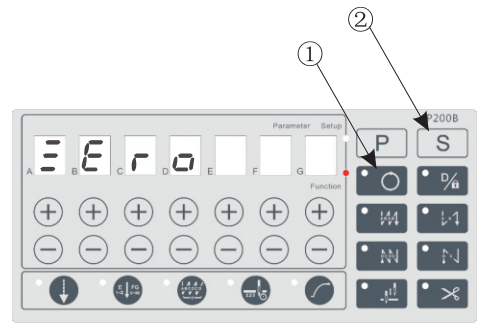

7. Lubrication (Fig.5)

1. Lubrication in the face plate

- 1). Remove face plate screw.
- 2). Open face plate ① as per illustration.
- 3). Drip oils to positions signed by arrows.
- 4). Close the face plate.
- 5). Tighten the screw.

2. Lubrication in the arm

- 1). Drip oils to the signed position by arrows everyday.
- 2). Oil the machine before its Initial running or after a long time idle at signed point and, remove top cover ②, drip oils to all felts and wicks inside the arm.

3. Small oil box

- 1). Connect the oil pipe ③ ④ with pump ⑤ and oil box ⑥
- 2). Fill oil into small oil box to the mark of HIGH.
- 3). Replenish oil in time when oil level is below LOW mark.
- 4). Run the sewing machine after oil filled, oil movement should be viewed from the oil window C. (Speed should be over 1500rpm)
- 5) if need to change oil, just pull out the plug ⑧

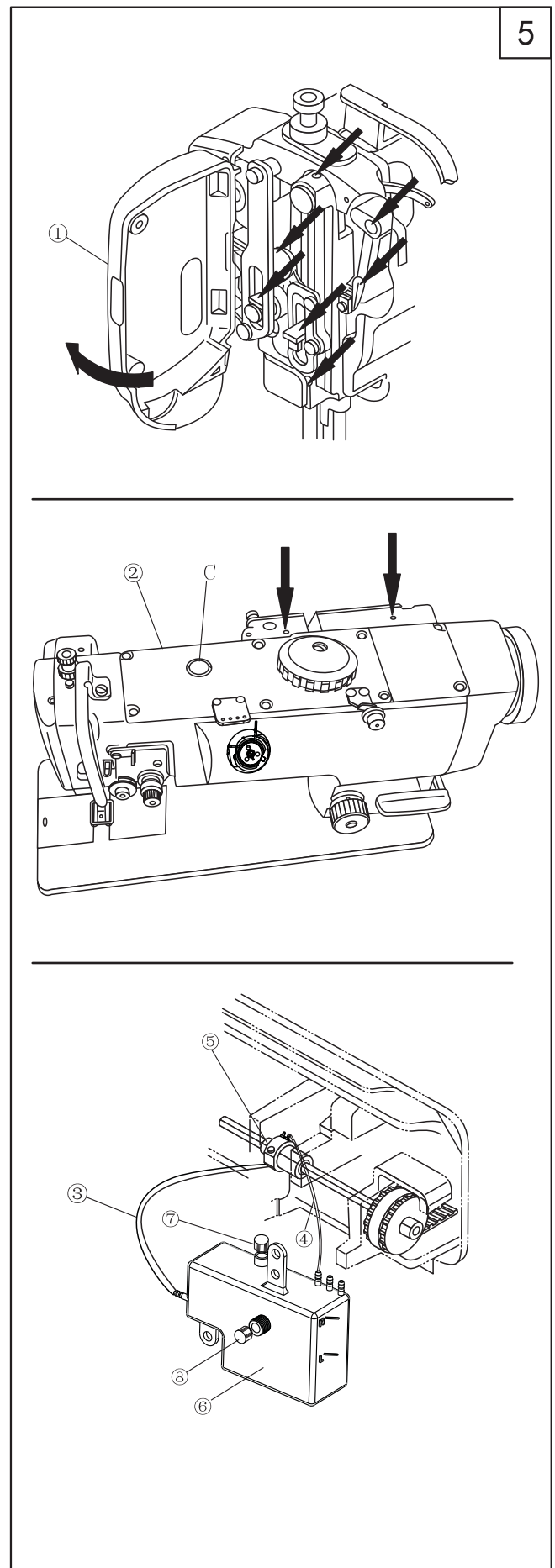

6

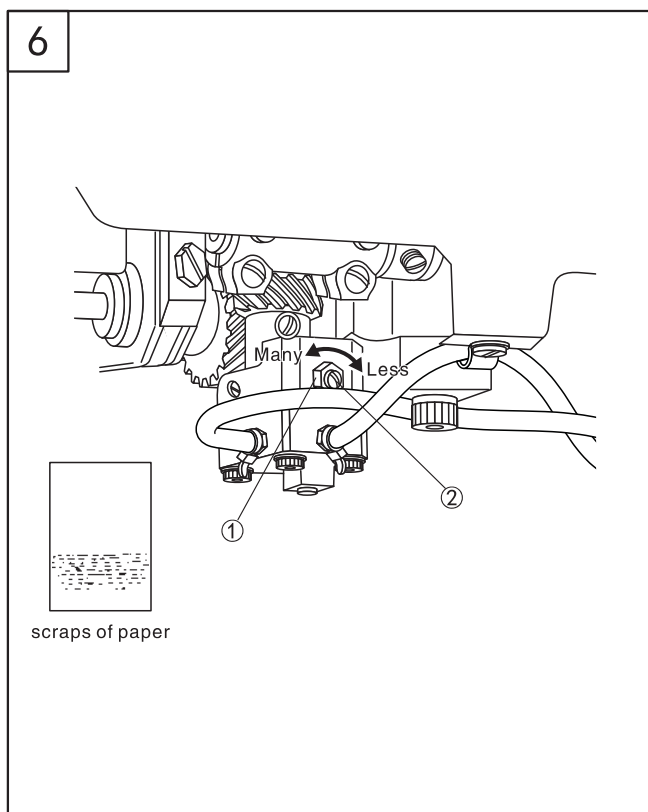

8. Adjusting the oil amount of hook (Fig.6)

1. Loosen the nut ①, turn the screw clockwise ② to decrease the oil amount, turn the screw counterclockwise to increase the oil amount
2. Put a paper sheet near hook about 5 seconds, if shown according to the fig6, then the suitable oil amount is required.

7

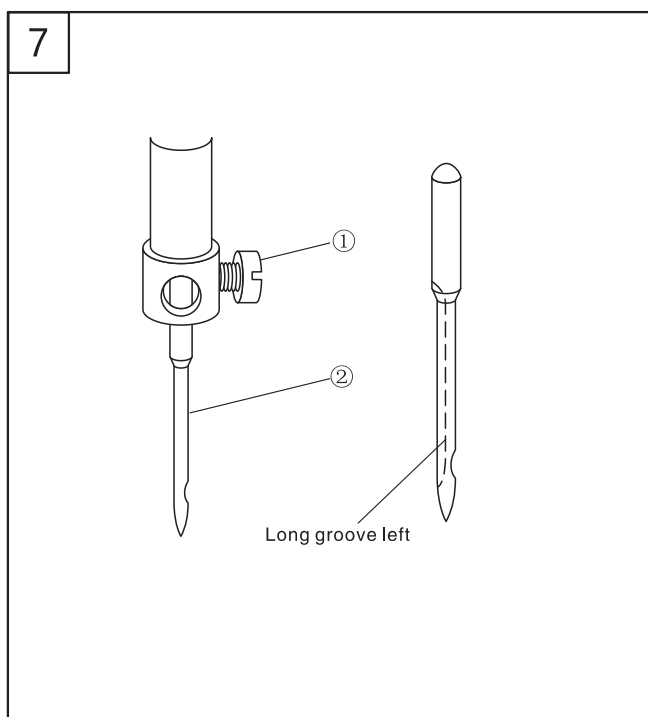

9. Setting the needle (Fig.7)

1. Turn the handwheel to raise the needle bar to its highest point.
2. Loosen needle set screw ② and have the long groove of the needle ① face leftward.
3. Insert needle fully.
4. Tighten the set screw ②.

8

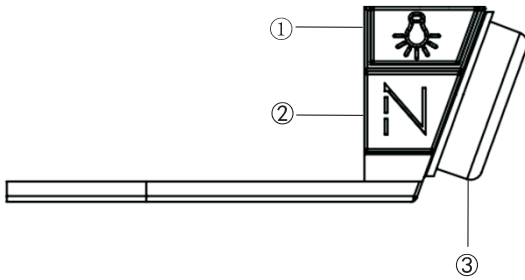

10. Function of reverse sewing switch (Fig.8)

- 1.Sewing light switch: press the button to control the light
- 2.Reverse sewing switch: hold the button to change the sewing direction
- 3.Electric handwheel: turn the handwheel to make the needle bar upward or downward, press the handwheel, the machine will be pause and tension will be release

9

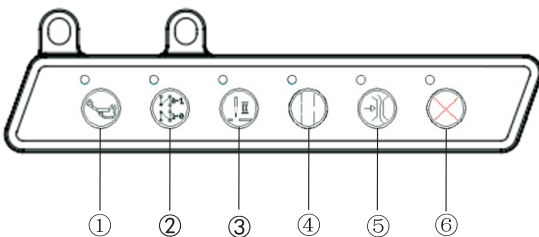

11. Function of manual switch (Fig.9)

- ① Alternating presser foot movement change switch
Machine can be switched between 2 different alternating presser foot movement amounts
● If the indicator is off, the alternating presser foot movement amount equals that set by dial
● If the indicator is on, the alternating presser foot movement amount equals the maximum amount
- ② Auto baktack select switch
If this switch is pressed when either start baktacking or end baktacking has been set to ON at the operation panel, baktacking is canceled for the first time only.
Furthermore, if this switch is pressed when neither start nor end baktacking has been set, baktacking is carried out for the first time only.
- ③ Half stitch switch
If this switch is pressed while the sewing machine has been stopped during sewing, the needle can then be moved up and down. (it will not move after thread trimming has been carried out.)
- ④ Thrust augmentation switch
Press the switch and increase the motor force.
- ⑤ Second tension release switch
When cross stitch, turn on the switch, then the second tension active
- ⑥ Safety switch
Press the key, the machine will stop for safety

12. Threading the bobbin (Fig.10)

- 1.Lift the latch ① and take out the bobbin.
- 2.Insert bobbin correctly and close the latch.
- 3.Draw bobbin thread through slot ②, tension spring and hole ③.
- 4.Bobbin should turn in the direction shown by the arrow when draw the bobbin thread.

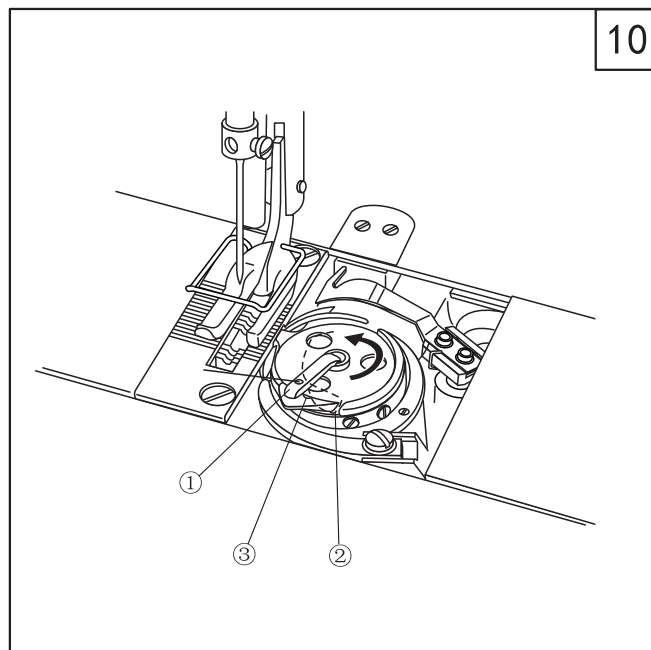

13. Installing the thread tension for bobbin thread winder(Fig.11)

Mount thread tension ① onto the top cover with set screw ②.

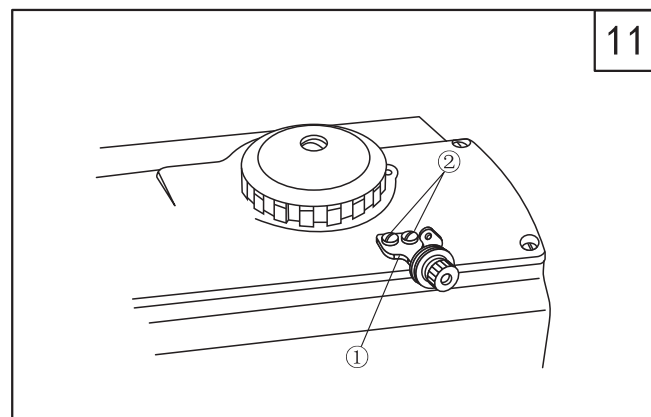

14. Winding bobbin thread (Fig.12)

- 1.Thread in sequence ①~④, then insert the bobbin A
- 2.Press latch C.
- 3.Loosen screw D to adjust the latch to get the proper thread amount of 90% of the bobbin capacity.
- 4.If thread wound unevenly, move guide E to regulate and fasten with screw F.
- 5.If the proper thread amount acquired, the latch will disengage automatically. pull out the bobbin and cut the thread, please note the thread end must be pressed under the cutter G.

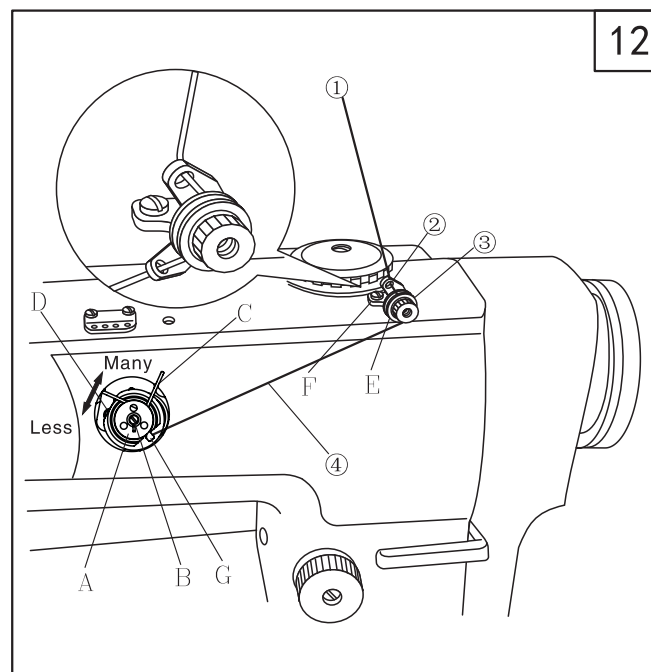

13

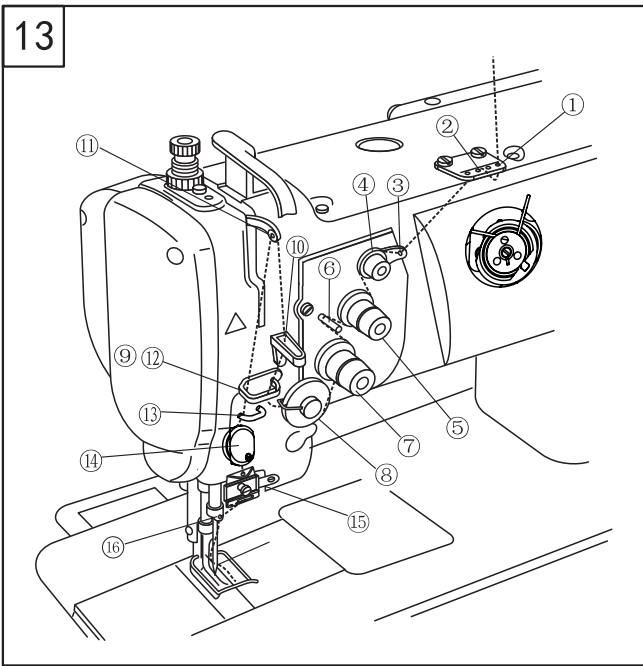

15. Threading the needle thread(Fig.13)

Press the electric handwheel, thread in sequence as shown in the illustration.

14

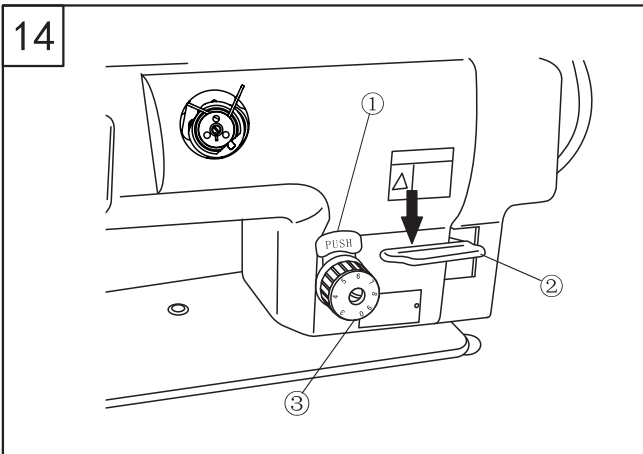

16. Stitch length (Fig.14)

Press the stopper ①, turn the stitch dial ③ leftward or rightward to get your required stitch length.

Press the reverse lever ② to start reverse sewing, loose it to restore normal sewing.

15

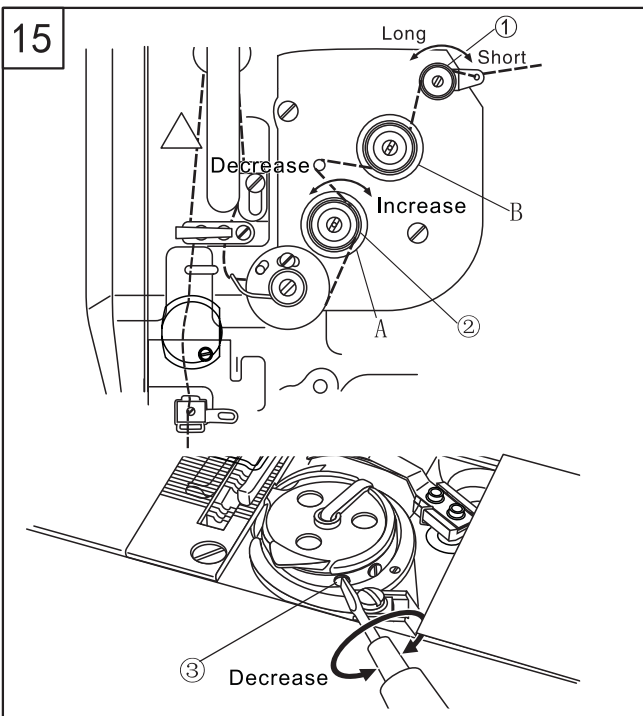

17. Thread tension (Fig.15)

1.Tension of needle thread

Turn the tension nut ① clockwise to short the thread remains after cut, turn counterclockwise to lengthen the thread remains.

Turn the tension nut ② clockwise to increase needle thread tension, turn counterclockwise to reduce the tension.

2.Tension of bobbin thread

Turn the tension nut ③ clockwise to increase bobbin thread tension, turn counterclockwise to reduce the tension.

18. Adjusting thread take-up spring (Fig.16)

1.To change the take-up spring swing range
a.Loosen set screw ② and move plate ③ to adjust the take-up spring.

b.Move plate ③ rightward to increase take-up spring swing range, move leftward to reduce swing range.

2.To change the tension of take-up spring

Loosen nut ④, turn shaft ⑤ counterclockwise to increase tension, turn clockwise to reduce the tension.

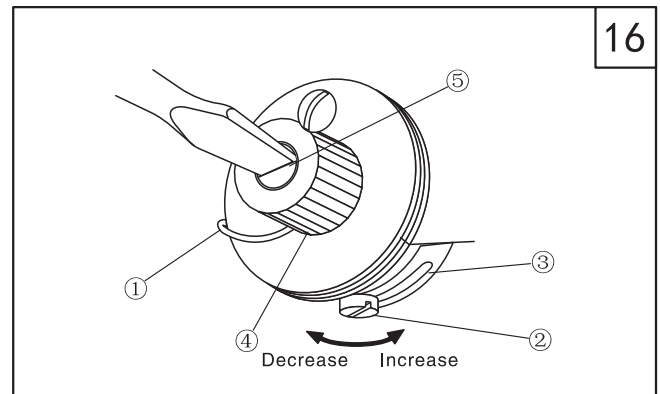

19. Presser foot lift (Fig.17)

1.When the presser foot on the lower resting position, raise the foot lift lever ① as illustration. The presser foot rises 9mm then stop.

2.Lower the lift lever ① to restore the presser foot.

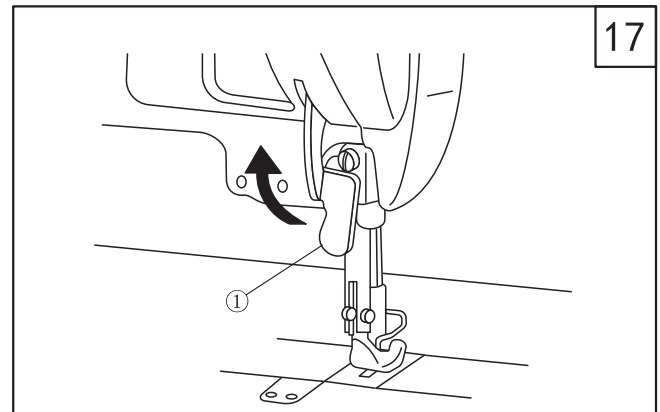

20. Pressure of presser foot (Fig.18)

Turn the regulating bolt ① rightward to increase the pressure, turn counterclockwise to reduce the pressure. Tighten nut ② after adjustment.

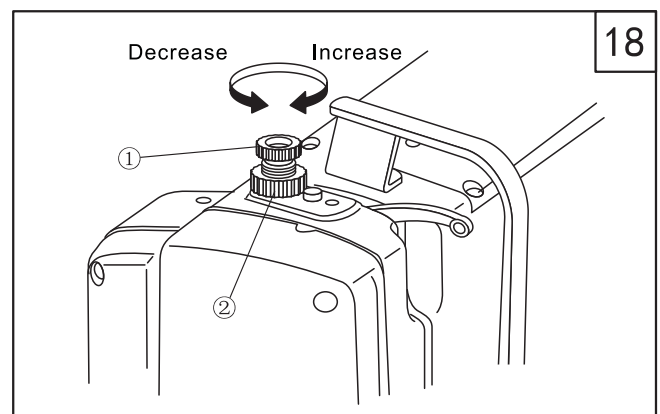

21. Adjusting needle guard plate (Fig.19)

Check the position of needle guard plate after change the rotating hook. The standard position of the guard plate ② is 0.1~0.2mm against needle ①. If the clearance is not right, bend the guard plate to adjust.

1.To bend the guard plate inward, insert a screwdriver outside.

2.To bend the guard plate outward, insert a screwdriver inside of the plate.

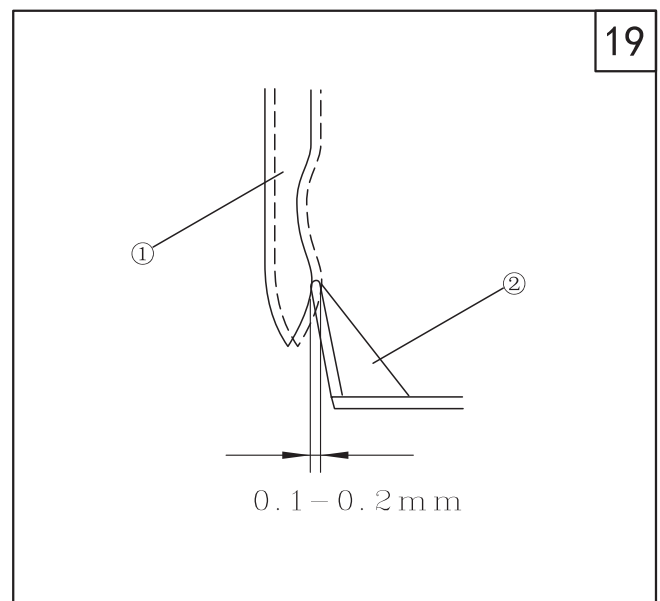

20

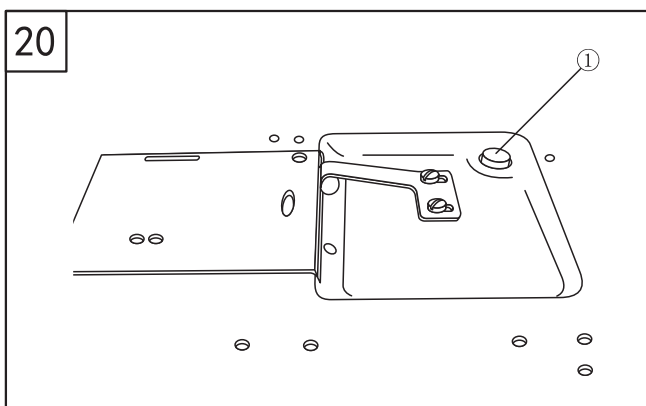

22. Reset of safety clutch (Fig.20)

In case the rotating hook is applied with a over strong force during operation, the safety clutch start working. The rotating hook stop turn even the handwheel is still turning. Check the machine and solve the problem, then reset the safety clutch.

1. Press button ① down on the bed, Firmly turn the handwheel reversely at the same time.
2. When a "click" sound is heard, the safety clutch is reset successfully.

21

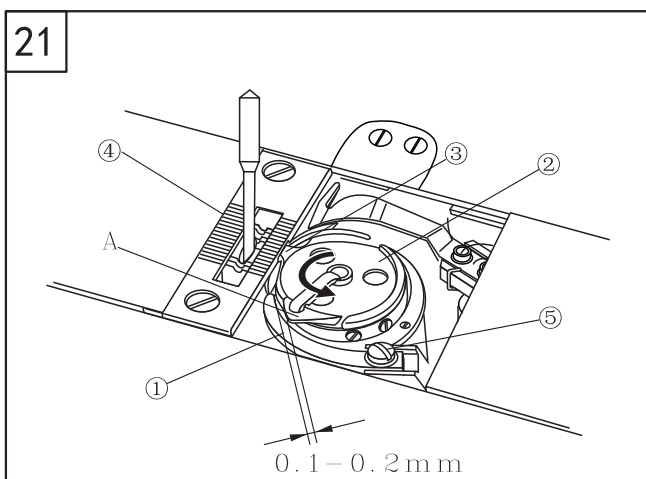

23. Adjusting hook thread opener (Fig.21)

1. Turn the handwheel in normal direction to move the thread opener ① to its ultimate position.
2. Turn the bobbin body ② in direction showed by arrow, to make stopper ③ (the projection part) against the notch under the bottom of the needle plate ④.
3. Adjust the clearance between horn A and the opener to 0.1~0.2mm, tighten the set screw ⑤

22

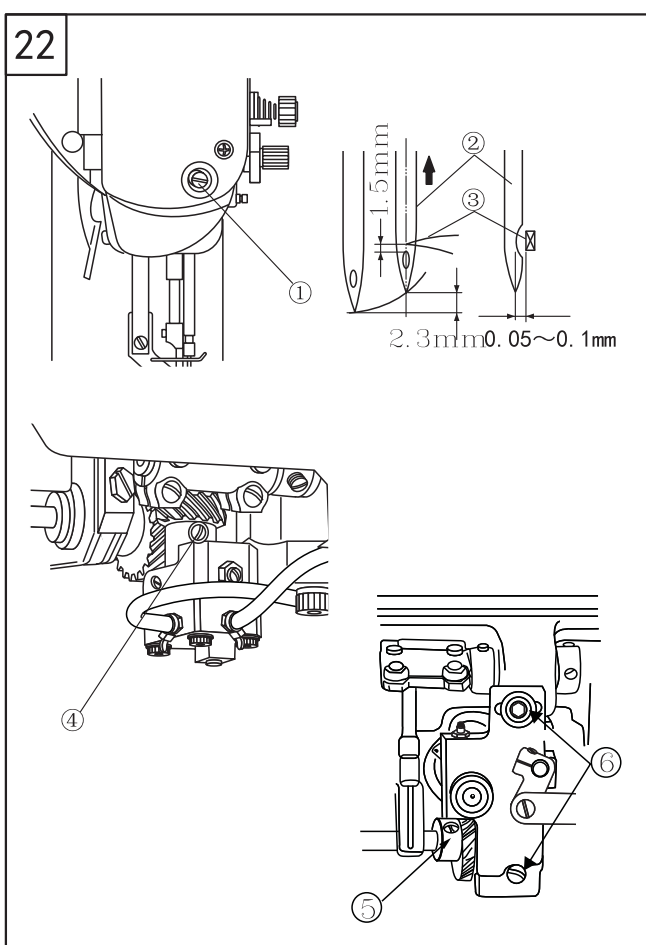

24. Timing between needle and rotating hook (Fig.22)

1. Turn the stitch dial to 0.
2. Turn the handwheel to raise needle bar by 2.3mm from its lowest point. Loosen needle bar joint screw ①, adjust the clearance between top of the needle hole and hoop tip to 1.5mm. Tighten screw ①.
3. Turn the handwheel to raise needle bar by 2.3mm from its lowest point. Adjust the hook tip ③ align with the center of the needle ② axis. Tighten the gear (small) two set screws, make sure that the first V-screw of two set screws align with the V-notch on the hook shaft.
4. When hook tip ③ aligned with the center of the needle ② axis, loosen the set screw ⑥ and move the hook saddle leftward or rightward to make the clearance between hook tip and needle to 0.05~0.1mm. Tighten screw ⑥.
5. Loosen the gear (big) two set screws ⑤, move gear (big) leftward or rightward to make the hook tip ③ align with the center of the needle ② axis. Tighten set screws ⑤, make sure that the first screw of two set screws aligns with the flat notch of the lower shaft.

25. Alternating lift amount of presser feet (Fig.23)

To adjust the lift amount of presser feet thru turn the dial ①

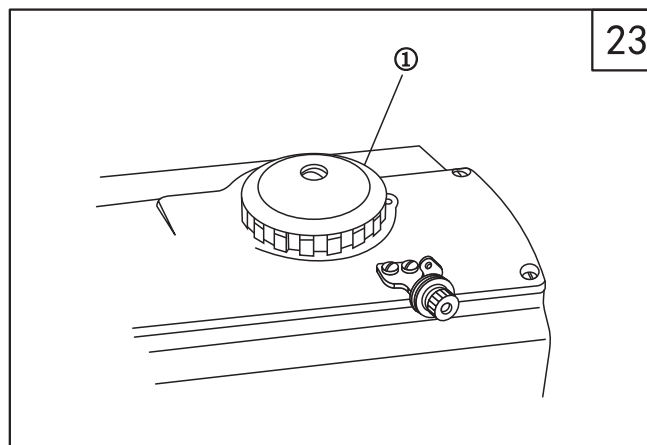

26. Setting the knee switch (Fig.24)

1. Install the bracket ① with screw ②
2. Adjust the knee switch ③ to suitable place, then tighten the screw ④
3. Connect the plug ⑤

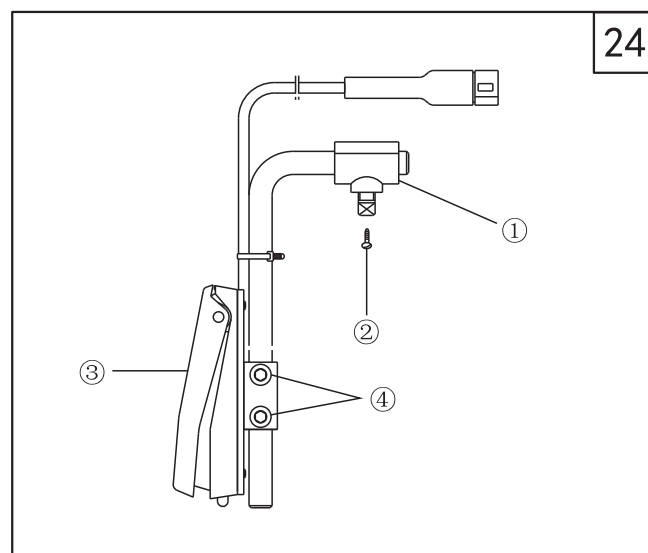

27. Adjusting the cutter (Fig. 25)

Adjust the position of fixed knife
Loosen the screw ①, the correct position is: the clearance between the front point of fixed knife and needle plate should be $1.5 \pm 0.2\text{mm}$ and the point should reach the project part of hook saddle, tighten the screw ①. Please use attached fixed knife gauge ③ to adjust the clearance.

Adjust the pressure of movable knife
Loosen the screw ②, turn the handwheel, when the clearance of front point between movable knife and fixed knife is 6–7mm, the pressure of movable knife is standard.

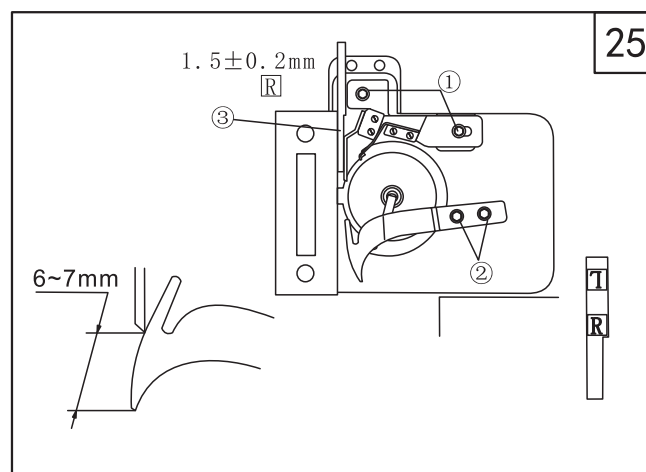

28. Stop position (Fig 26)

Align the mark ① on the motor cover with the mark ② on the handwheel, the meaning of every stop position, please refer to below table.

Mark on the handwheel	
White-white	Needle up
Yellow	Needle down
Red	For adjusting the cutting driven cam

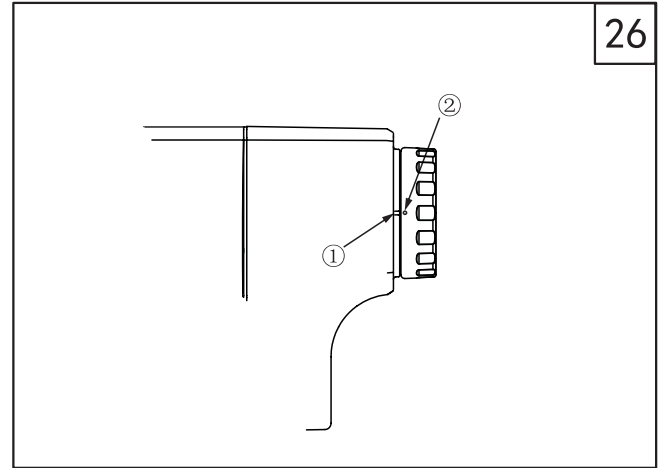

29. Pedal operation and standing operation (Fig 27)

If need to standing operation, please extra buy the standing pedal ① and transform connector ②, connect the transform connector ② to the plug ④ of control box, then set the parameter as below:

1. Press the key "-" ⑤ and power on, the panel will display "PEDAL X", the mean of X is:

0: foot pedal(default)

1: standing pedal

2. Press the key "+" ⑥ to change the setting number of X, then press "S": to save, restart the system.

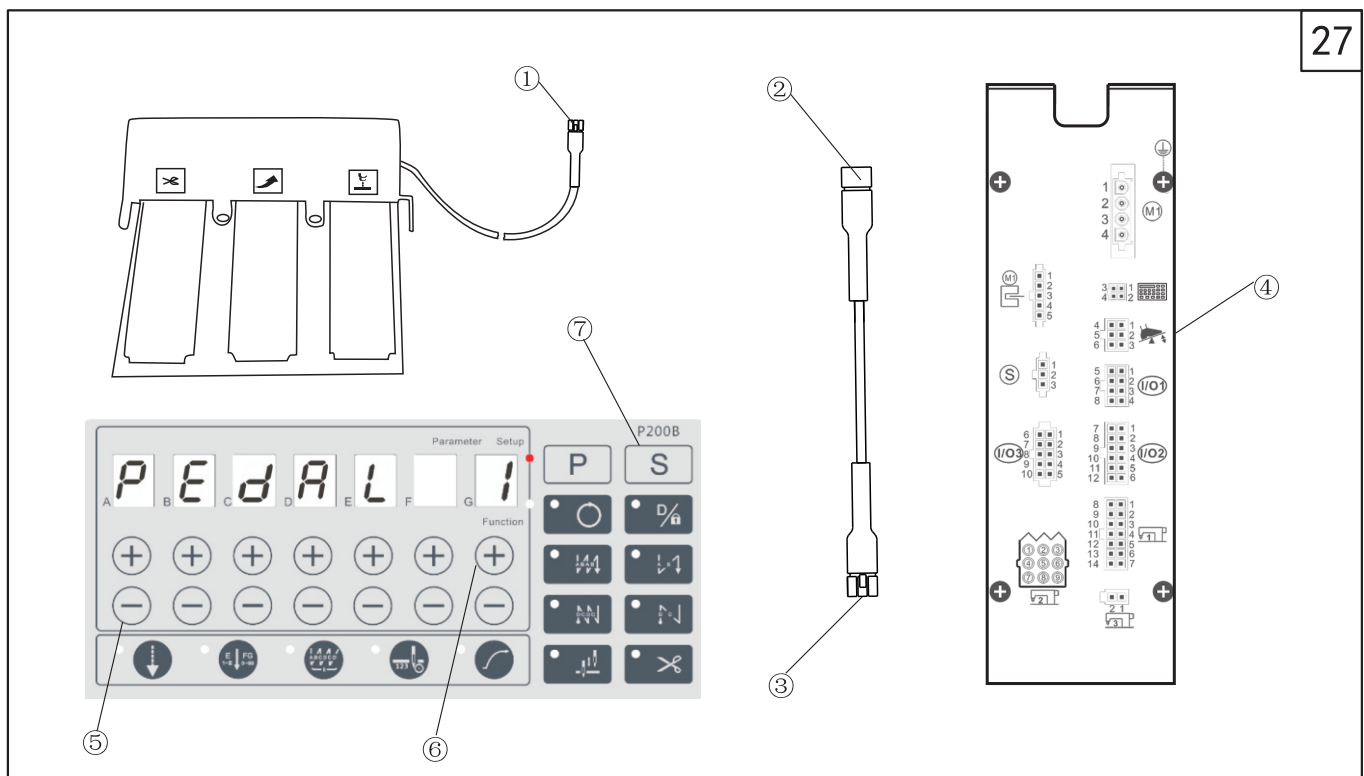

30. Settings for different speeds

Alternating lift amount	Speed
Less than 2.5mm	2,500rpm
2.5~4mm	2,000rpm
4~4.75mm	1,800rpm
4.75~6.5mm	1,500rpm

Make proper settings for different speeds accordingly. Do not surpass the standard.

Parts Manual

1. Casting mechanism

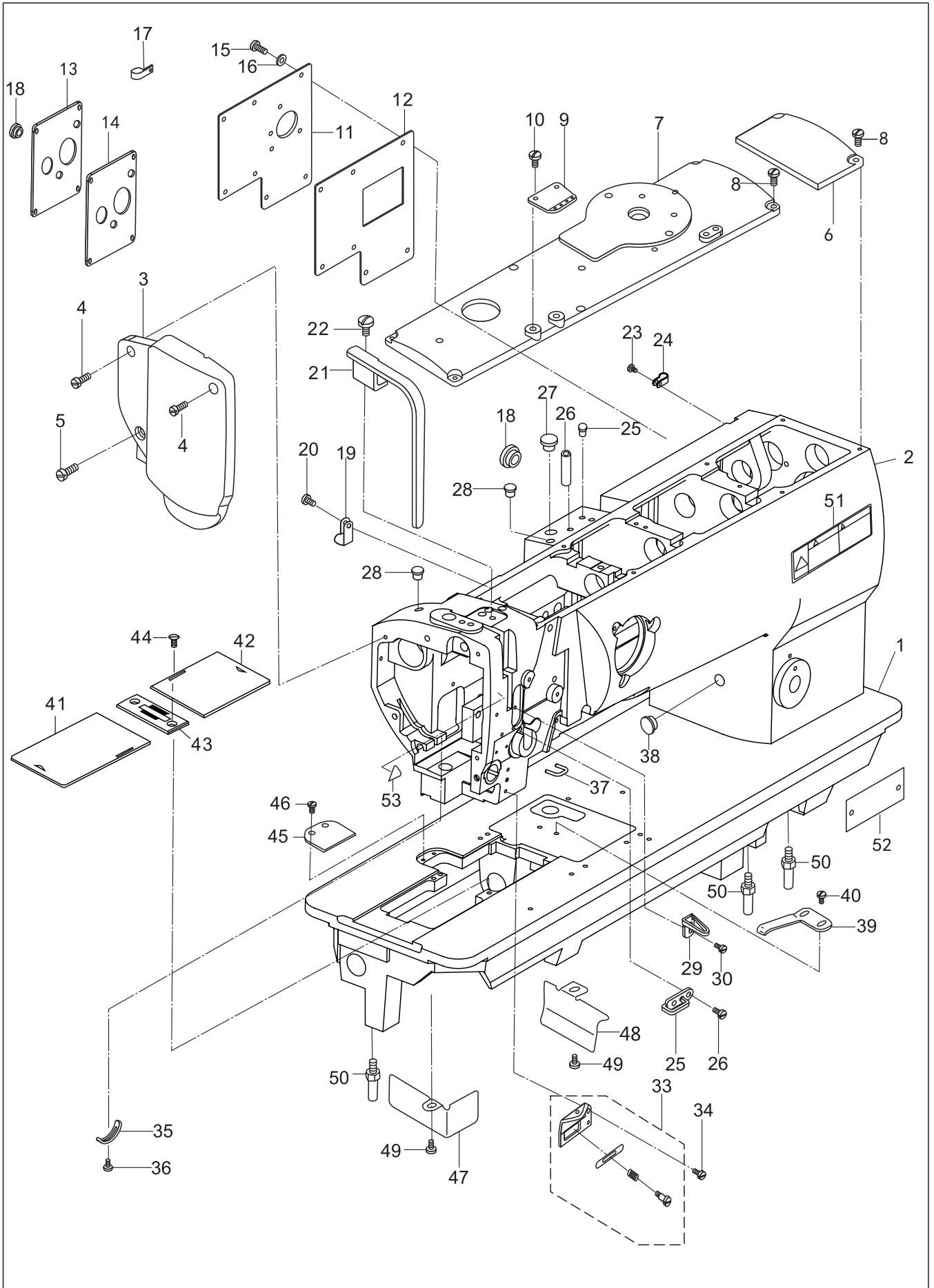

1. Casting mechanism

No.	Part Number	Name	Qt.	Remark
1	312WF2-001	Bed	1	
2	444WF2-001	Arm	1	
3	92WF2-003	Face plate assy	1	
4	1WF5-039	Screw	2	SM11/64"×40
5	26210	Screw	1	SM15/64"×28
6	406WF2-002	Top cover, R	1	
7	312WF2-003	Top cover, L	1	
8	1WF1-011	Screw	8	SM11/64"×40
9	199WF2-017	Upper thread guide	1	
10	21WF1-062	Screw	2	SM3/16"×32
11	119WF2-003	Back cover	1	
12	119WF2-004	Seal	1	
13	259WF-003	Back cover, R	1	
14	259WF-004	Seal	1	
15	1WF5-039	Screw	11	SM11/64"×40
16	22T1-007	Washer	11	
17	119WF2-008	Wire clamp	3	
18	92WF2-030	Rubber plug	3	
19	84WF1-021	Wire clamp	2	
20	1WF1-011	Screw	2	SM11/64"×40
21	92WF2-004	Thread take-up lever cover	1	
22	13WF2-045	Screw	1	SM15/64"×28
23	22WF5-027	Screw	1	SM11/64"×40
24	119WF2-008	Wire clamp	1	
25	199WF2-015	Rubber clamp	2	
26		Pin	1	GB/T879.1 4.5X20
27	92WF2-028	Rubber plug	1	
28	92WF2-029	Rubber plug	2	
29	238WF1-003	Thread guide	1	
30	22T1-003C6	Screw	1	SM9/64"×40
31	238WF1-004	Thread guide	1	
32	1WF1-007	Screw	1	SM9/64"×40
33	385WF2-005	Lower thread guide assy.	1	
34	22T1-003C6	Screw	1	
35	50WF2-022	Stopper plate	1	

1. Casting mechanism

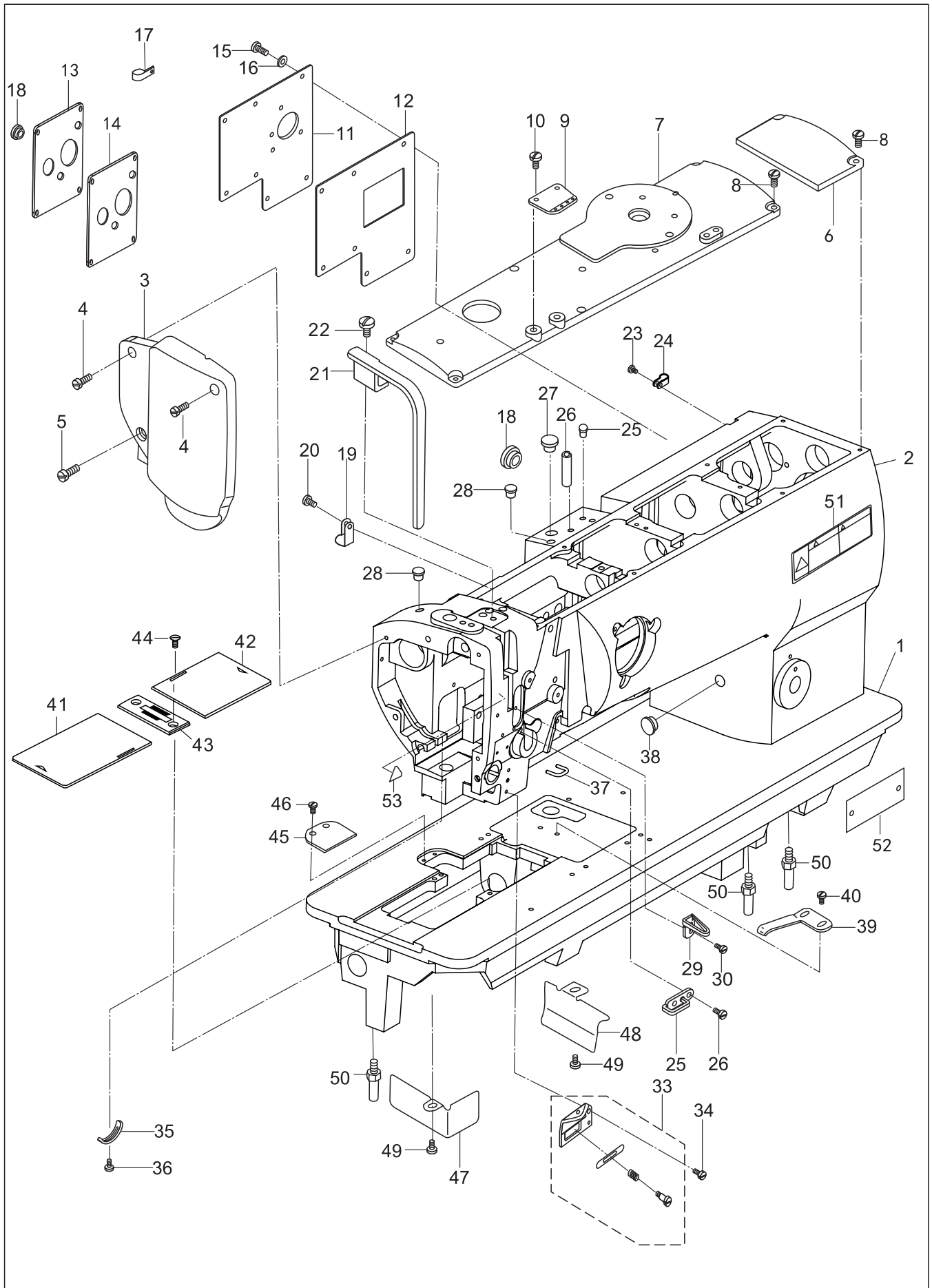

1. Casting mechanism

No.	Part Number	Name	Qt.	Remark
36	1WF1-026	Screw	1	SM9/64"×40
37	385WF2-006	Thread guide, U type	1	
38	92WF2-028	Rubber plug	1	
39	199WF2-004	Leaf spring	1	
40	22T2-019	screw	2	
41	199WF2-007	Sliding plate (L)	1	
42	199WF2-008	Sliding plate (R)	1	
43	199WF2-005	Needle plate	1	
44	199WF2-006	Screw	2	
45	228WF2-002	Plate	1	
46	50WF2-031	Screw	2	SM9/64"×40
47	199WF2-003	Auxiliary plate	1	
48	199WF2-009	Oil stopper	1	SM11/64"×40
49	21WF4-047	Screw	2	
50	199WF2-010	Screw	3	
51	7WF4-031	Caution label	1	
52	7WF4-034	Model plate	1	
53	59WF1-010	Caution label	1	
			1	

2. Arm shaft & thread take-up mechanism

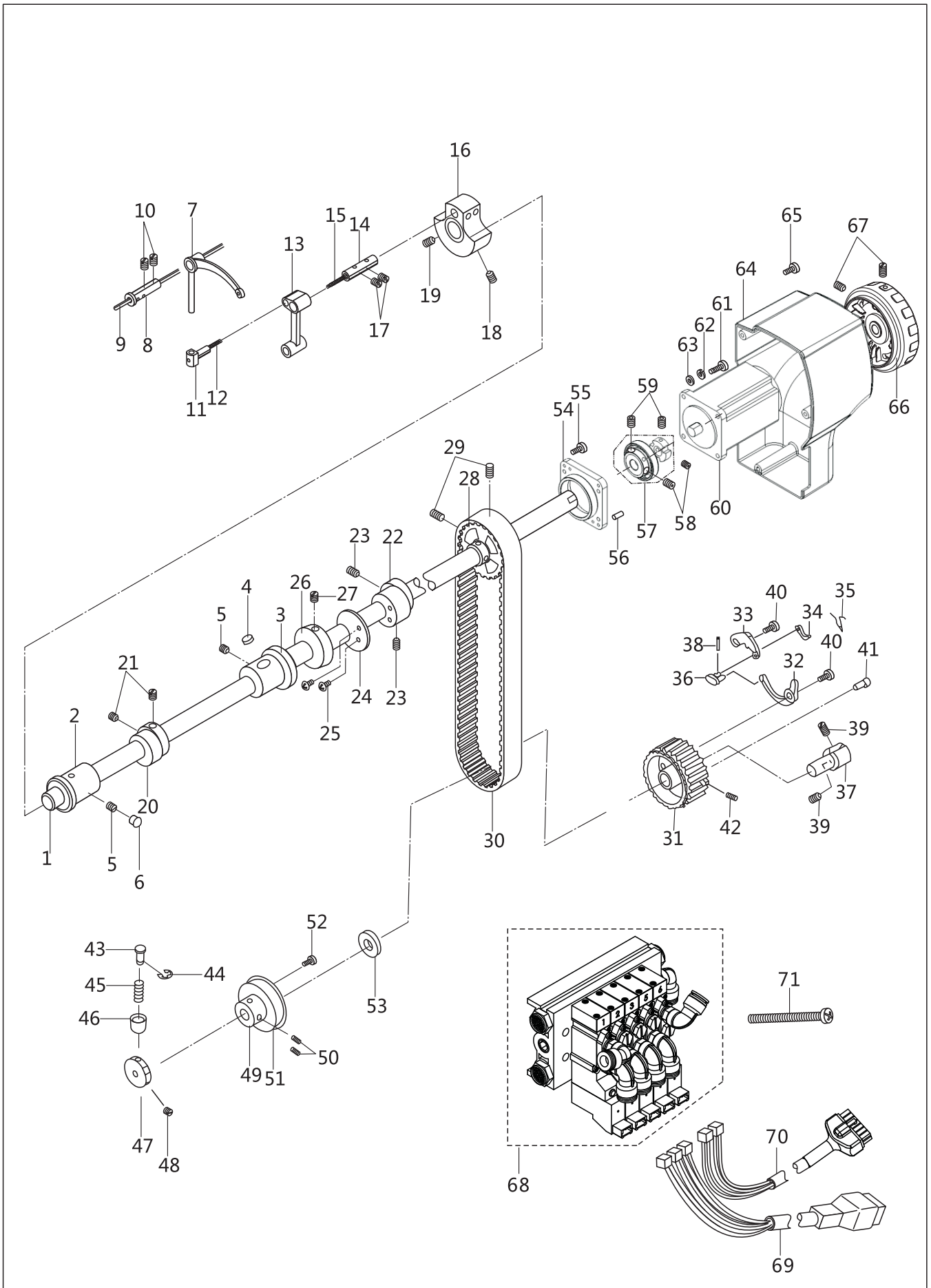

2. Arm shaft & thread take-up mechanism

No.	Part Number	Name	Qt.	Remark
1	406WF1-001	Arm shaft	1	
2	385WF1-002	Bushing, L	1	
3	406WF1-002	Bushing, M	1	
4	220WF1-004	Oil felt	1	
5	1WF5-019	Screw	2	SM15/64 " X28
6	92WF2-029	Rubber plug	1	
7	199WF1-001A	Thread take-up lever	1	
8	16WF1-010	Pin shaft	1	
9	199WF1-003	Oil wick	1	Φ2.5×450
10	17WF4-016	Screw	2	SM15/64"×28
11	50WF1-006	Link	1	
12	199WF1-004	Oil wick	1	30
13	92WF1-006	Needle bar link	1	
14	50WF1-008	Pin shaft	1	
15	199WF1-005	Oil wick	1	Φ7×30
16	92WF1-007	Needle bar crank	1	
17	42WF3-007	Screw	2	SM15/64"×28
18	50WF1-013	Screw	1	SM9/32"×28
19	20T2-007	Screw	1	SM9/32"×28
20	92WF3-014	Feed cam	1	
21	199WF3-010	Screw	2	SM1/4"×40
22	92WF3-029A	Feed eccentric cam	1	
23	199WF3-010	Screw	2	SM1/4"×40
24	92WF3-030	Feed cam cover plate	1	
25	7WF5-017	Screw	2	SM11/64"×40
26	385WF1-004	Collar	1	
27	42WF1-010	Screw	2	M5×6
28	199WF1-002	Pulley, arm shaft	1	
29	92WF1-014	Screw	2	
30	92WF1-034	Teeth belt	1	
31	110WF1-017	Pulley, lower shaft	1	
32	22WF1-013	Clutch plate	2	
33	22WF1-018	Stop plate	1	
34	22WF1-016	Plate	1	

2. Arm shaft & thread take-up mechanism

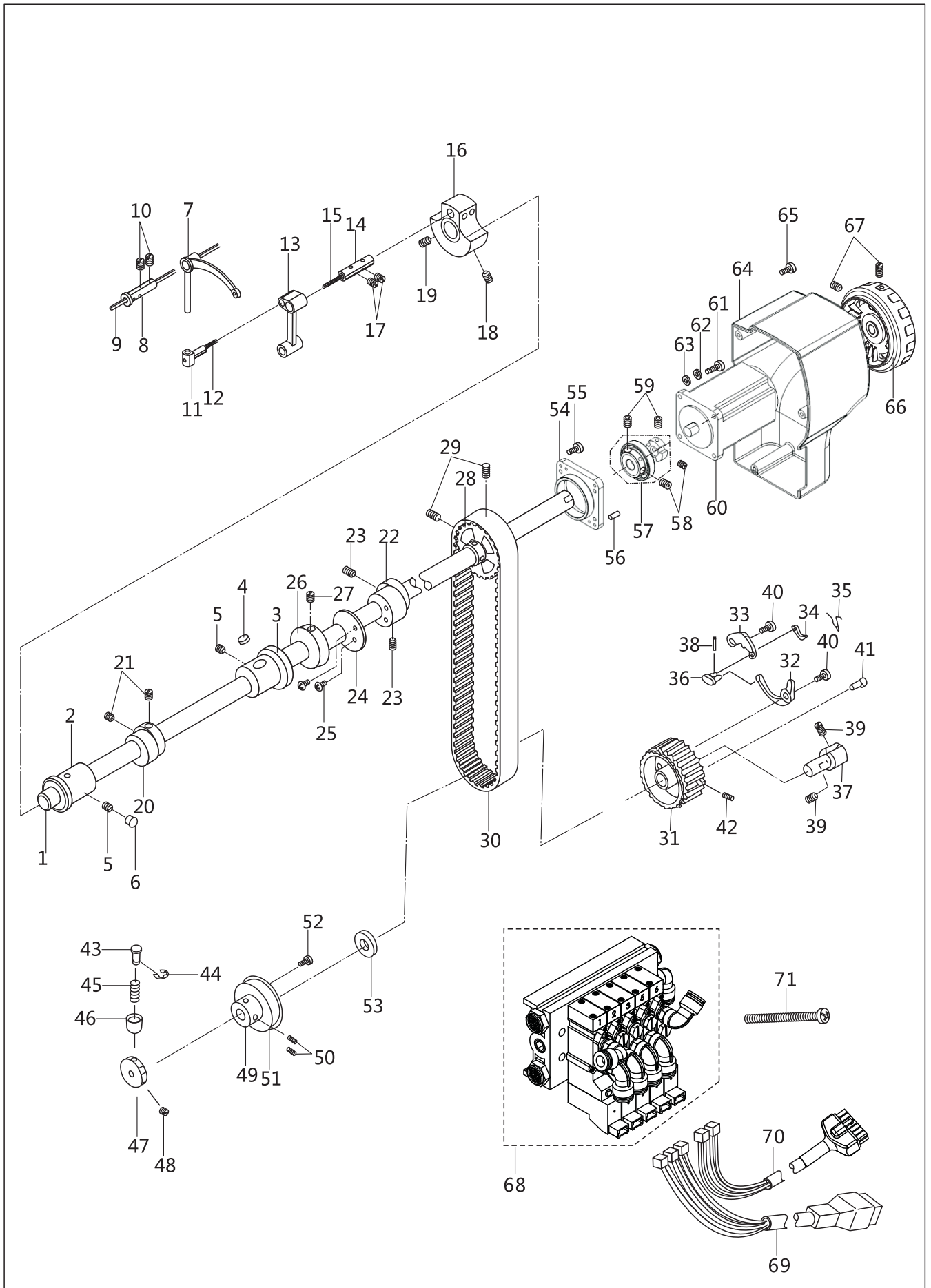

2. Arm shaft & thread take-up mechanism

No.	Part Number	Name	Qt.	Remark
35	22WF1-014	Twist spring	1	
36	22WF1-017	Link	1	
37	199WF1-015	Bushing	1	
38	B225001	Pin	1	GB/T91 1.2X8
39	199WF1-054	Screw	2	SM1/4"×40
40	22WF1-019	Screw	2	
41	22WF1-015	Pin	1	
42	22WF1-020	Screw	2	
43	199WF1-020	Push button	1	
44		Retaining ring	1	GB896 5
45	199WF1-021	Spring	1	
46	199WF1-022	Bushing	1	
47	199WF1-023	Wheel	1	
48	18227	Screw	1	SM1/4"×40
49	199WF1-024	Collar	1	
50	21WF1-022	Screw	2	SM1/4"×40
51		Ball bearing	1	50104 20×42×12
52	199WF1-025	Screw	2	SM3/16"×28
53	199WF1-026	Washer	2	
54	385WF1-009	Motor base	1	
55	93WF7-014	Screw	4	M5×14
56		Pin	2	GB/T 117 5×22
57	385WF1-005	Coupling	1	
58	394WF2-006	Screw	2	M6×0.75×8
59	93WF15-012	Screw	2	M6×0.75×8
60	394WF2-003	Motor	1	
61	80WF6-025	Screw	4	M5×20
62		Washer	4	GB 859 5
63		Washer	4	GB/T97.1 5
64	385WF1-006	Motor cover	1	
65	80WF6-025	Screw	3	M5×20
66	258WF2-006	Handwheel	1	
67	258WF2-007	Screw	2	GB/T80 M5×8
68	444WF4-001	Electric valve assy.	1	
69	385WF5-007	Wire assy.	1	
70	444WF4-002	Wire assy.	1	
71		Screw	3	GB/T818 M4×30

3. Needle bar rocking frame mechanism

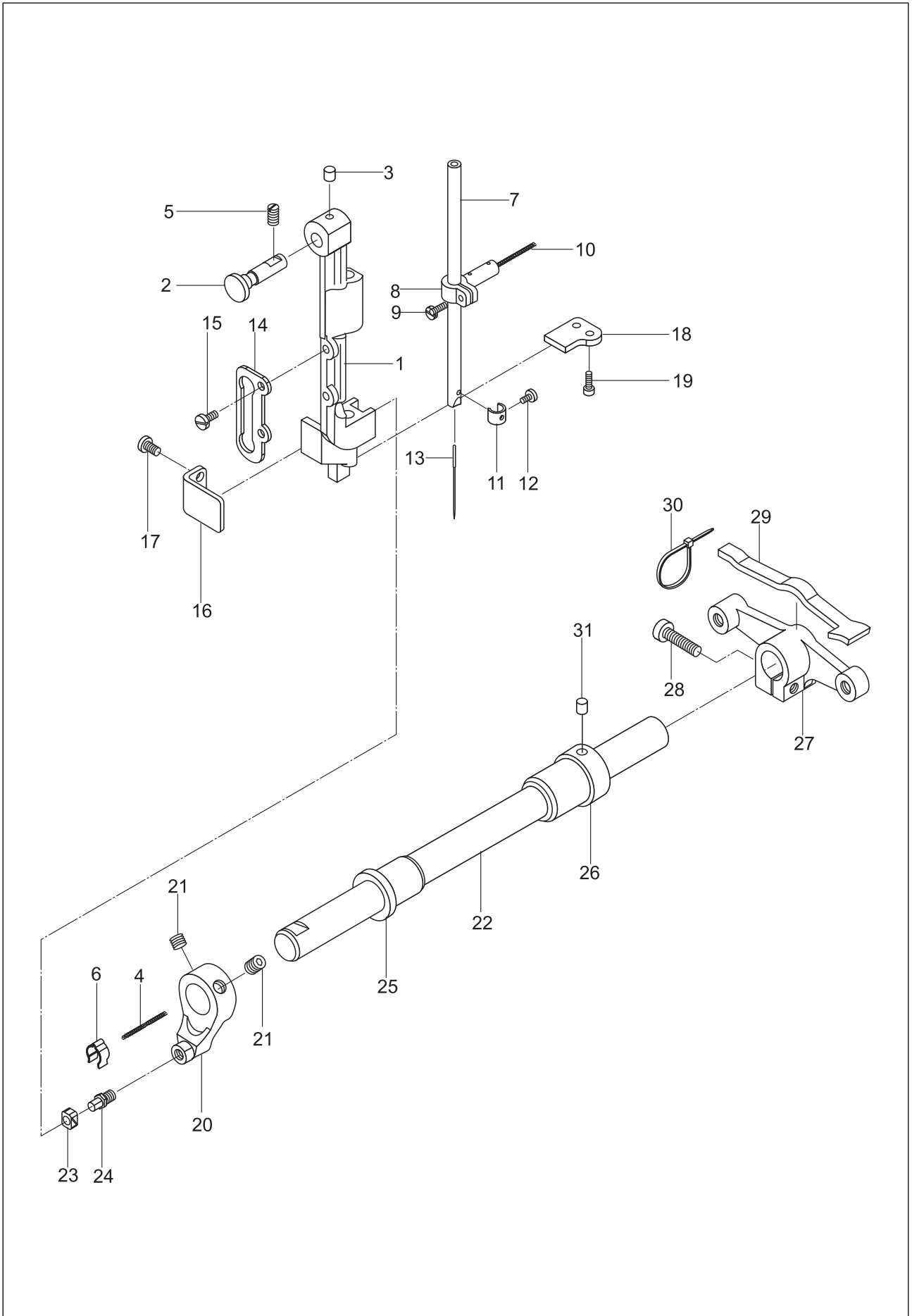

3. Needle bar rocking frame mechanism

No.	Part Number	Name	Qt.	Remark
1	92WF3-008	Needle bar rocking frame	1	
2	92WF3-009	Pin	1	
3	92WF3-007	Oil felt	1	
4	199WF3-001	Oil wick	1	Φ2×160
5	42WF3-007	Screw	1	SM15/64"×28
6	92WF3-003	Leaf spring	1	
7	50WF1-001	Needle bar	1	
8	50WF3-003	Needle bar joint	1	
9	36WF3-029B	Screw	1	
10	199WF3-002	Oil wick	1	Φ6×20
11	92WF1-003	Needle bar thread guide	1	
12	199WF1-055	Screw	1	SM1/8"×44
13		Needle	1	DP×17 23#
14	50WF3-030	Guide rail	1	
15	1WF1-011	Screw	2	SM11/64"×40
16	92WF3-011	Position plate (2)	1	
17	W01111	Screw	2	SM11/64"×40
18	92WF3-010	Position plate (1)	1	
19	21WF1-054	Screw	2	SM9/64"×40
20	92WF3-002A	Crank	1	
21	92WF3-070	Screw	2	
22	312WF3-001	Rocking shaft	1	
23	92WF3-004	Slide block	1	
24	92WF3-002B	Pin	1	
25	92WF3-005	Bushing , L	1	
26	92WF3-006	Bushing, R	1	
27	92WF3-012	Crank	1	
28	52WF1-050	Screw	1	
29	92WF3-013	Oil felt	1	
30	2KT-001A	Band	1	
31	92WF3-007	Oil felt	1	

4. Upper feed mechanism

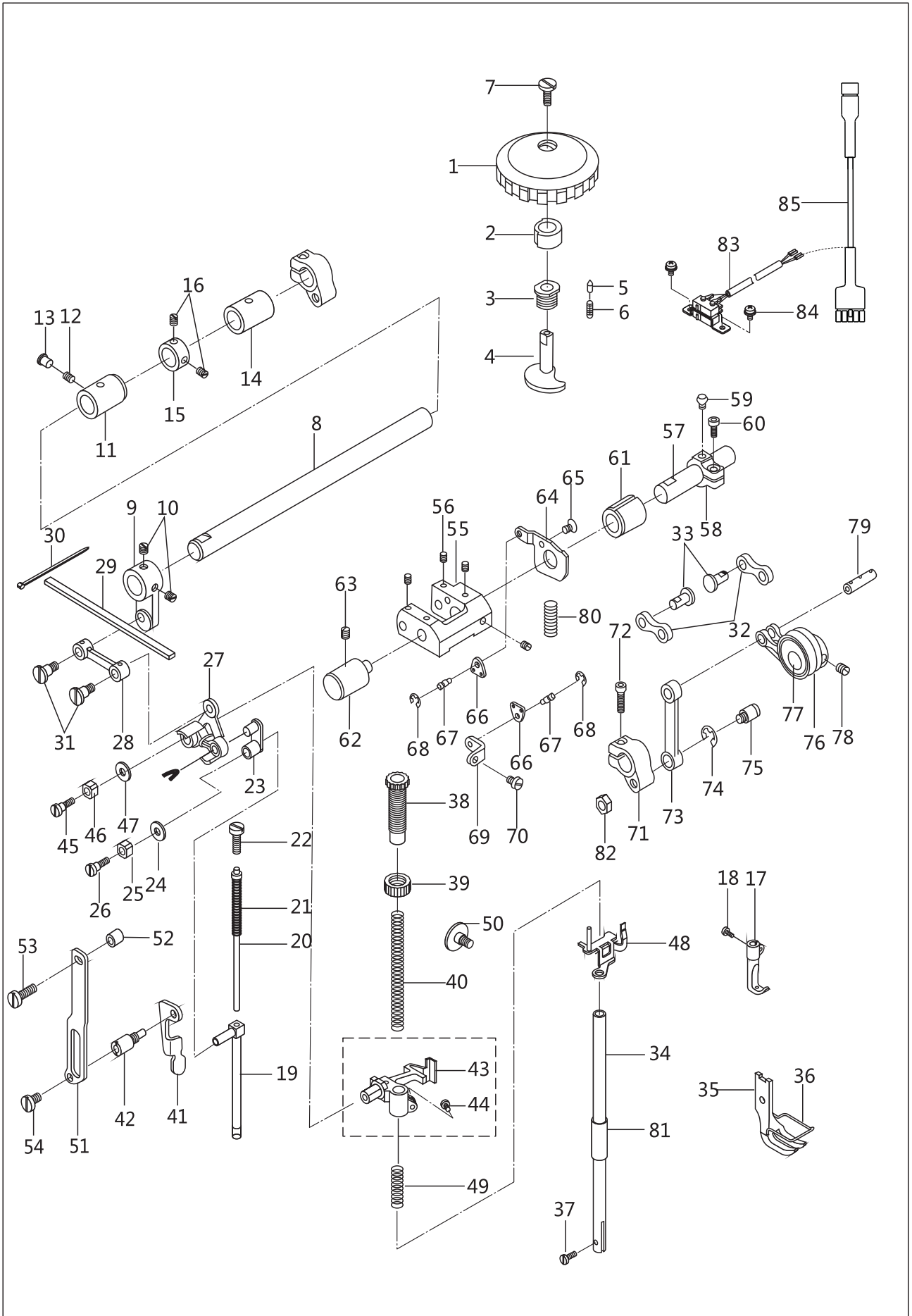

4. Upper feed mechanism

No.	Part Number	Name	Qt.	Remark
1	119WF7-017A	Dial	1	
2	119WF7-017B	Bushing	1	
3	119WF7-019	Bushing	1	
4	119WF7-018	Shaft	1	
5	199WF4-002	Pin	1	
6	93WF8-002	Spring	1	
7	302395	Screw	1	
8	92WF3-018	Shaft	1	
9	92WF3-019	Crank	1	
10	2KT5-027	Screw	2	SM1/4"×40
11	199WF4-001	Front bushing	1	
12	1WF5-019	Screw	1	SM15/64"×28
13	92WF2-029	Rubber plug	1	
14	92WF3-021	Rear bushing	1	
15	92WF3-022	Collar	1	
16	22T3-002B2	Screw	2	SM1/4"×40
17	92WF3-023	Walking foot	1	
18	50WF3-020	Screw	1	
19	50WF3-018	Walking foot lifting bar	1	
20	92WF3-024	Spring guide bar assy.	1	
21	50WF3-032	Spring	1	
22	60WF4-003	Regulating screw	1	SM15/64"×28
23	199WF4-003	Link	1	
24	50WF3-028	Felt	1	
25	50WF3-029	Slide block	1	
26	20T4-006	Screw	1	SM11/64"×40
27	92WF3-025	Lifting plate	1	
28	92WF3-026	Link	1	
29	92WF3-027	Oil felt	2	
30	2KT7-001A	Band	2	
31	92WF3-028	Screw	2	
32	119WF7-011	Link	2	
33	994118	Pin shaft	1	
34	22WF3-005	Presser bar	1	
35	92WF4-001	Presser foot	1	
36	92WF4-002	Finger guard	1	
37	22WF3-014	Screw	1	SM9/64"×40
38	92WF4-003	Regulating bolt	1	SM1/2"×28
39	1KT4-002	Nut	1	SM1/2"×28
40	92WF4-023	Spring	1	
41	385WF3-001	Foot lifting bar	1	
42	92WF4-005	Lifting bar shaft	1	

4. Upper feed mechanism

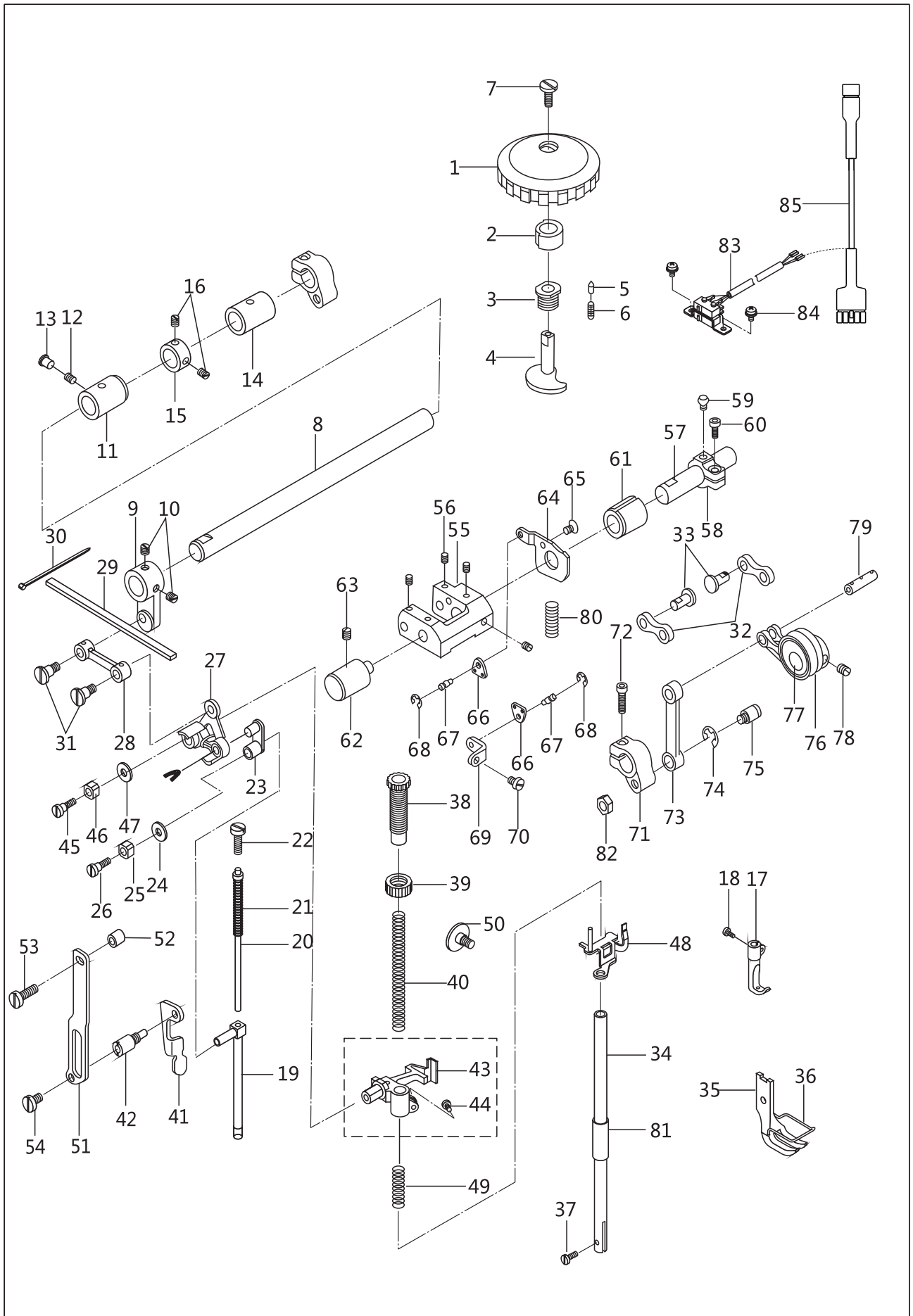

4. Upper feed mechanism

No.	Part Number	Name	Qt.	Remark
43	92WF4-006	Bracket	1	
44	1WF1-011	Screw	1	SM11/64"×40
45	92WF4-007	Screw	1	
46	50WF3-029	Slide block	1	
47	92WF4-008	Washer	1	
48	92WF4-009	Releasing plate	1	
49	50WF4-013	Spring	1	
50	50WF4-014	Screw	1	
51	92WF4-010	Guide plate	1	
52	92WF4-011	Washer	1	
53	60WF4-003	Screw(U)	1	SM15/64"×28
54	52WF3-027	Screw(L)	1	SM15/64"×28
55	119WF7-001	Adjusting bracket	1	
56	6K2-043	Screw	4	SM15/64"×28
57	119WF7-003	Shaft	1	
58	119WF7-004	Crank	1	
59	119WF7-005	Screw	1	
60	72WF5-021	Screw	1	
61	119WF7-002	Bushing	1	
62	92WF3-037	Shaft	1	
63	1WF5-019	Screw	1	
64	259WF-011	Retaining plate	1	
65		Screw	1	GB/T819.2 M5×8
66	119WF7-014	Connecting plate	2	
67	119WF7-015	Screw	2	
68		Retaining ring	2	GB896 5
69	119WF7-016	Hanger	1	
70	50WF3-089	Screw	1	
71	119WF7-009	Crank	1	
72	80WF6-025	Screw	1	
73	119WF7-008B	Link	1	
74		Retaining ring	1	GB896 8
75	119WF7-010	Screw	1	
76	119WF7-008A	Link	1	
77	119WF7-007	Needle bearing	1	
78	21WF1-022	Screw	1	
79	119WF7-008C	Pin shaft	1	
80	119WF7-013	Spring	1	
81	50WF4-001	Bushing	1	
82	7WF5-001	Nut	1	
83	119WF7-020	Speed adjusting assy.	1	
84		Screw	2	GB/T65 M4X8
85	385WF5-010	Knee switch connector	1	

5. Lower feed, reverse and feed regulating

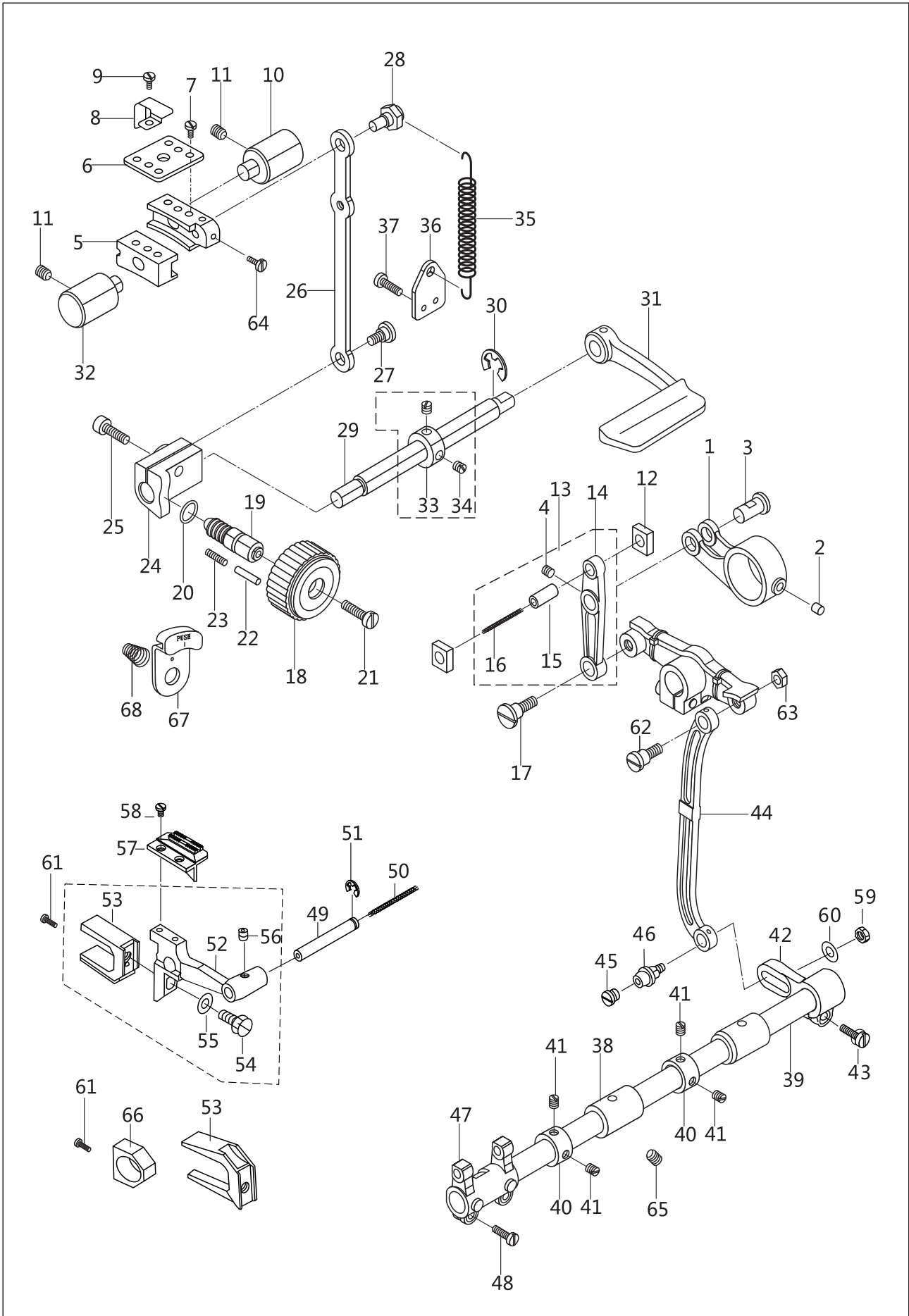

5. Lower feed, reverse and feed regulating

No.	Part Number	Name	Qt.	Remark
1	92WF3-031	Feed link	1	
2	92WF3-032	Oil felt	1	
3	92WF3-033	Pin	1	
4	6K2-043	Screw	1	M5
5	238WF3-006	Reverse feed bracket	1	
6	238WF3-005	Retaining plate	2	
7	1WF1-011	Screw	4	
8	238WF3-007	Presser plate	1	
9	33T3-006	Screw	2	
10	92WF3-074	Shaft	1	
11	1WF5-019	Screw	2	SM15/64"×28
12	238WF3-004	Slide block	2	
13	92WF3-039	Feed rocking bar assy.	1	
14	92WF3-039A	Feed rocking bar	1	
15	92WF3-039B	Pin	1	
16	199WF3-003	Oil wick	1	Φ1.5×35
17	92WF3-040	Screw	1	
18	92WF3-041	Stitch regulating dial	1	
19	92WF3-042	Screw bar	1	
20	92WF3-043	Seal ring	1	
21	92WF3-044	Screw	1	SM3/16"×28
22	92WF3-072	Stop pin	1	
23	50WF3-058	Spring	1	
24	92WF3-045	Holder	1	
25	6K2-024	Screw	1	M6
26	92WF3-046	Link	1	
27	92WF3-047	Screw	1	
28	92WF3-048	Eccentric pin	1	
29	385WF6-001	Reverse feed lever shaft	1	
30	92WF3-071	Retaining ring	1	GB896 9
31	92WF3-050	Reverse feed lever	1	
32	248WF5-020	Shaft	1	
33	92WF3-052	Collar	1	
34	22T3-002B2	Screw	2	SM1/4"×40
35	92WF3-053	Spring	1	
36	92WF3-054	Spring hook	1	
37	1WF3-009	Screw	2	SM11/64"×40
38	92WF3-021	Feed shaft bushing	2	

5. Lower feed, reverse and feed regulating

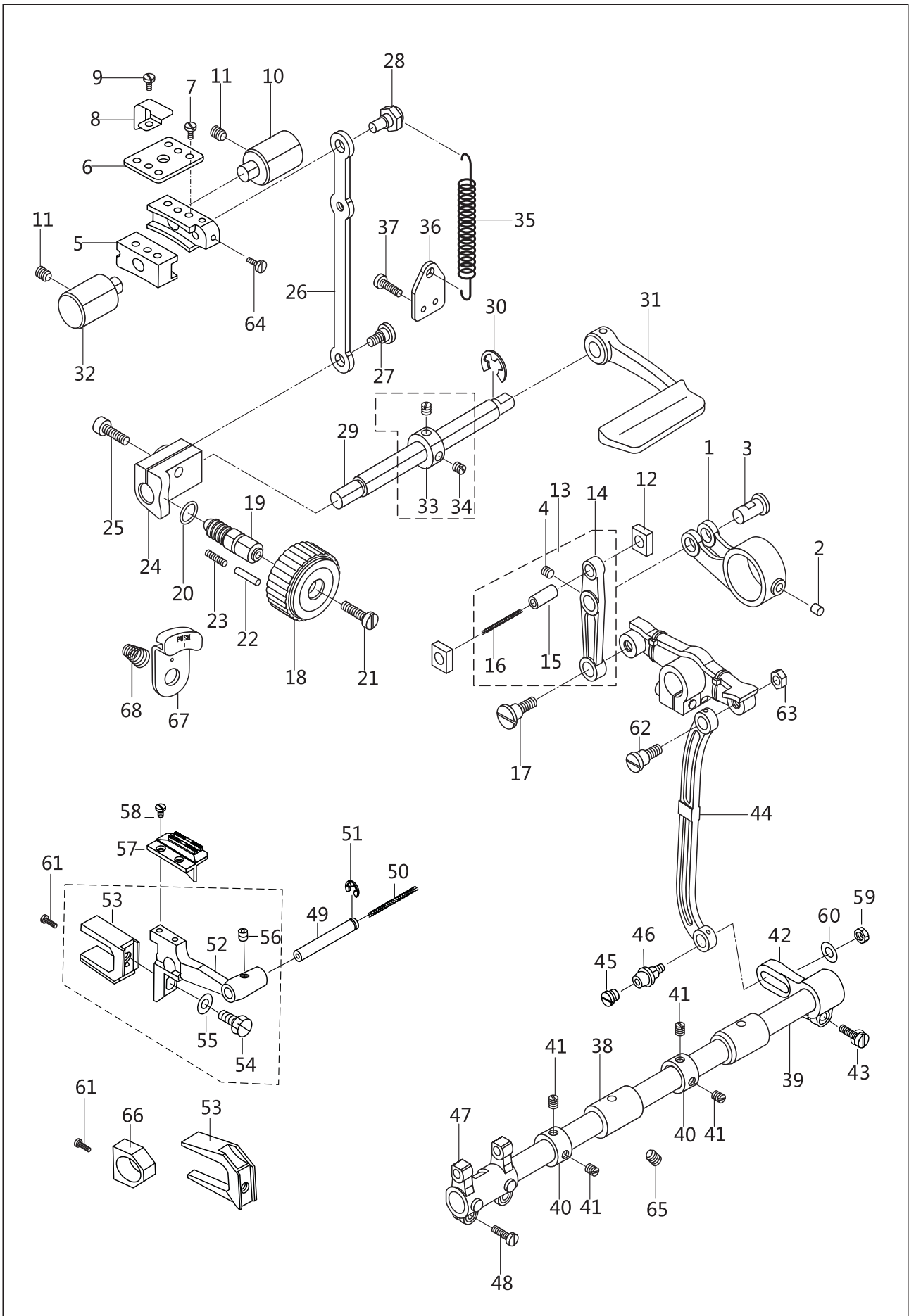

5. Lower feed, reverse and feed regulating

No.	Part Number	Name	Qt.	Remark
39	312WF3-002	Feed shaft	1	
40	92WF3-022	Feed shaft collar	2	
41	22T3-002B2	Screw	4	SM1/4"×40
42	119WF3-001	Driving crank	1	
43	41WF3-018	Screw	1	SM3/16"×28
44	92WF3-058	Link	1	
45	119WF3-003	Screw	1	
46	119WF3-002	Screw	1	
47	92WF3-060	Feed crank	1	
48	1WF3-009	Screw	2	SM11/64"×40
49	92WF3-061	Pin	1	
50	199WF3-004	Oil wick	1	Φ2.5×120
51		Retaining ring	1	GB896 5
52	199WF3-005	Feed dog support	1	
53	204WF3-007	Lifting fork	1	
54	42WF1-008	Screw	1	SM15/64"×28
55	42WF1-009	Washer	1	
56	80WF6-036	Screw	1	
57	199WF3-007	Feed dog	1	
58	199WF3-008	Screw	2	
59	22WF3-004	Nut	1	
60	71WF3-058	Washer	1	
61	13WF6-008	Screw	1	
62	92WF3-059	Screw	1	
63	6KT2-053	Nut	1	
64	36WF3-029B	Screw	2	
65	17WF4-016	Screw	2	
66	204WF3-008	Slide block	1	
67	92WF3-071	Stopper	1	
68	36T5-011	Spring	1	

6. Lower shaft and rotating hook

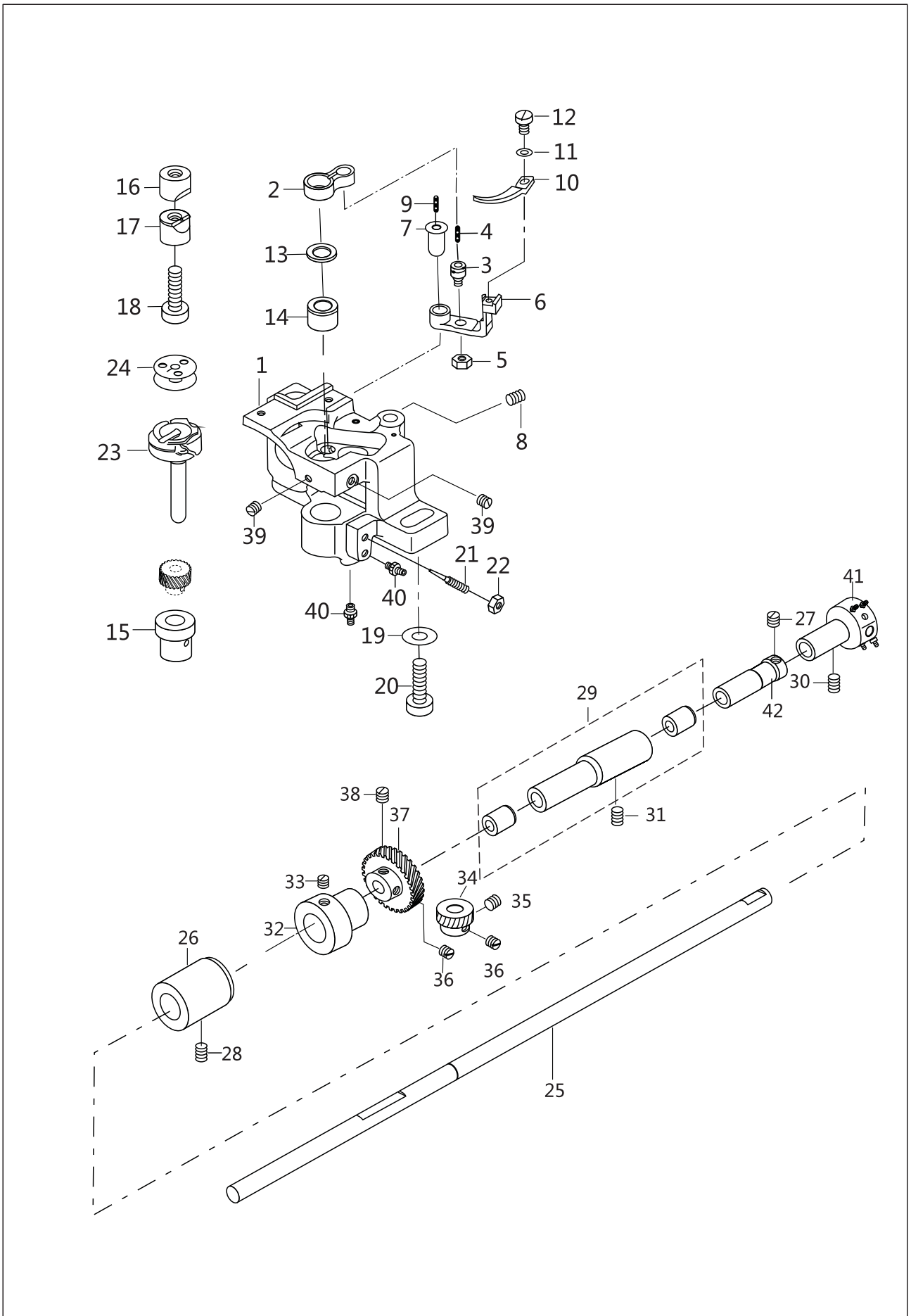

6. Lower shaft and rotating hook

No.	Part Number	Name	Qt.	Remark
1	228WF1-002	Rotating hook saddle	1	
2	199WF1-028A	Thread opener link	1	
3	199WF1-029	Pin	1	
4	199WF1-030	Oil wick	1	
5	27WF4-008	Nut	1	Φ3×15
6	228WF1-003	Thread opener supporter	1	
7	228WF1-004	Shaft	1	
8	52WF2-030	Screw	1	SM11/64"×40
9	199WF1-033	Oil wick	1	Φ3×20
10	228WF1-005	Thread opener	1	
11	36WF1-042	Washer	1	
12	21WF2-038	Screw	1	SM9/64"×40
13	228WF1-006	Washer(optional)	1	1.7~1.8
	199WF1-035	Washer(optional)	1	1.1~1.6
14	228WF1-007	Upper bushing, rotating hook	1	
15	199WF1-037	Lower bushing, rotating hook	1	
16	199WF1-038	Block A	1	
17	199WF1-039	Block B	1	
18	1WF2-060	Bolt	1	
19	199WF1-040	Washer	1	
20		Bolt	1	GB/T 70.1 M8×40
21	92WF1-031	Screw	1	
22	27WF4-008	Nut	1	
23	228WF1-008	Rotating hook assy.	1	
24	228WF1-011	Bobbin	1	
25	312WF1-002	Lower shaft	1	
26	312WF1-003	Left bushing, lower shaft	1	
27	2KT5-027	Screw	3	SM1/4"×40
28	17WF4-016	Screw	1	SM15/64"×28
29	312WF1-004	Middle bushing assy., lower shaft	1	
30	17WF4-016	Screw	1	SM15/64"×28
31	17WF4-016	Screw	1	SM15/64"×28
32	238WF2-004A	Feed dog lifting cam	1	
33	21WF3-010	Screw	2	SM15/64"×28
34	199WF1-046	Rotating hook shaft gear	1	
35	21WF1-033	Screw	1	SM1/4"×40
36	21WF1-043	Screw	1	SM1/4"×40
37	199WF1-047	Lower shaft gear	1	
38	1WF2-010	Screw	2	SM1/4"×40
39	36WF5-021	Screw	2	SM11/64"×40
40	199WF1-048	Oil tube connector	2	
41	199WF1-056	Bushing	1	
42	199WF1-057	Shaft, oil pump	1	

7. Thread tension components

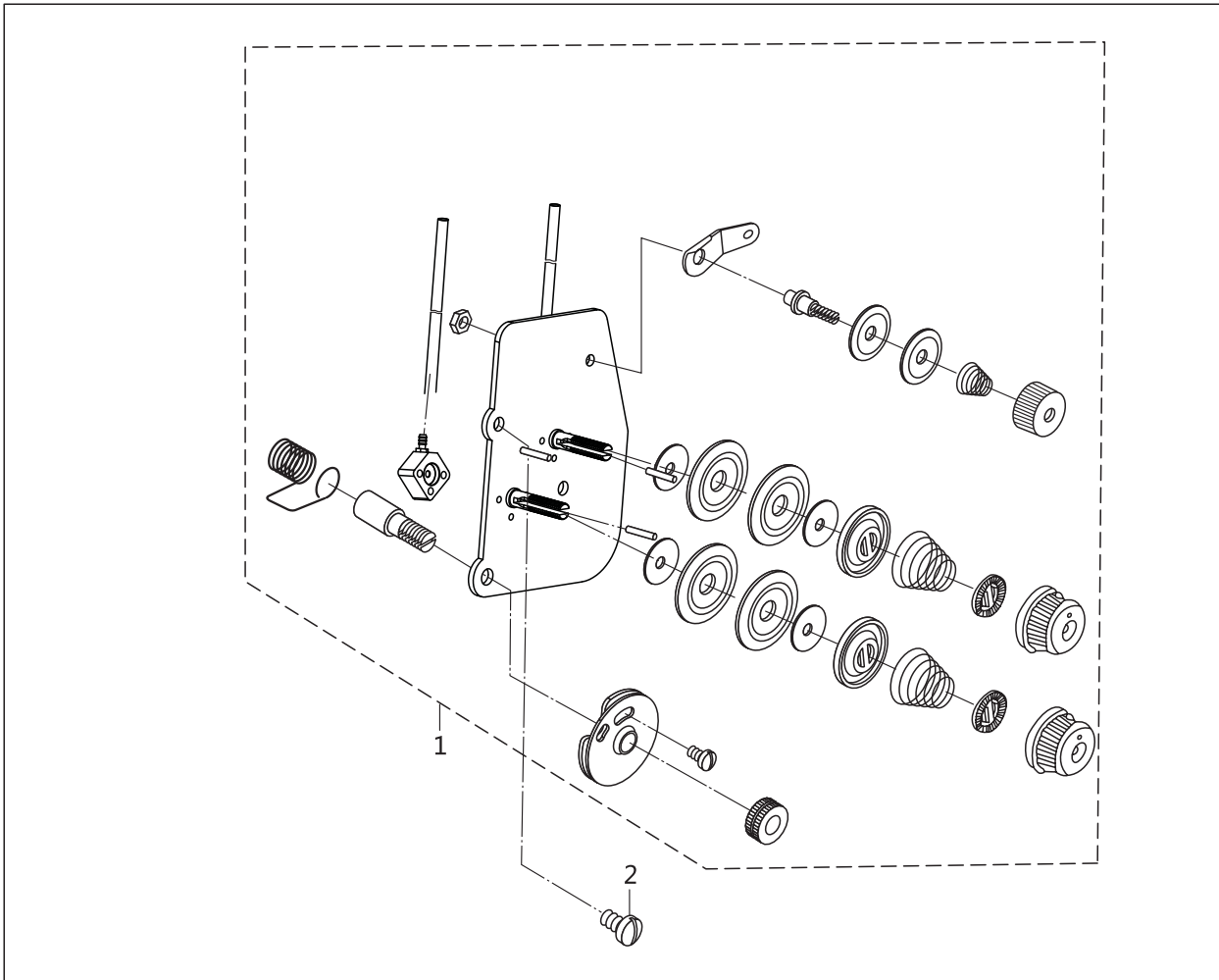

No.	Part Number	Name	Qt.	Remark
1	385WF2-004	Thread tension assy.	1	
2	1WF1-016	Screw	2	SM11/64 " X40

8. Bobbin winder & thread nipper components

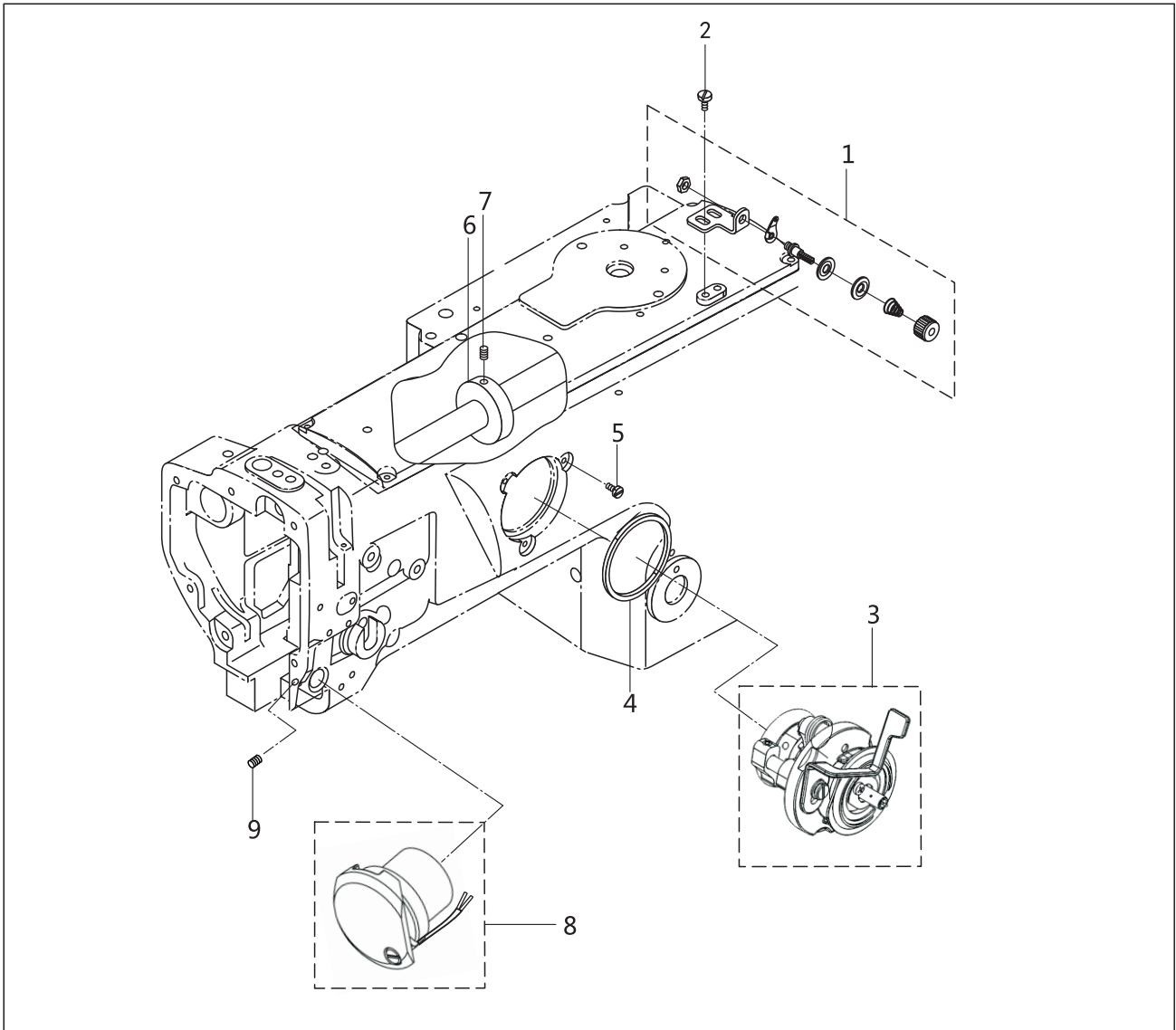

No.	Part Number	Name	Qt.	Remark
1	92WF2-021	Bobbin thread tension assy.	1	
2	13WF2-040	Screw shaft	2	M4
3	385WF2-001	Thread winder assy.	1	
4	92WF2-026	Seal ring	1	
5	92WF2-027	Screw	3	SM11/64"×40
6	92WF2-035	Friction wheel	1	
7	6K2-043	Screw	2	
8	385WF2-003	Thread nipper	1	
9	21WF1-060	Screw	1	SM11/64"×40

9. Thread trimming mechanism

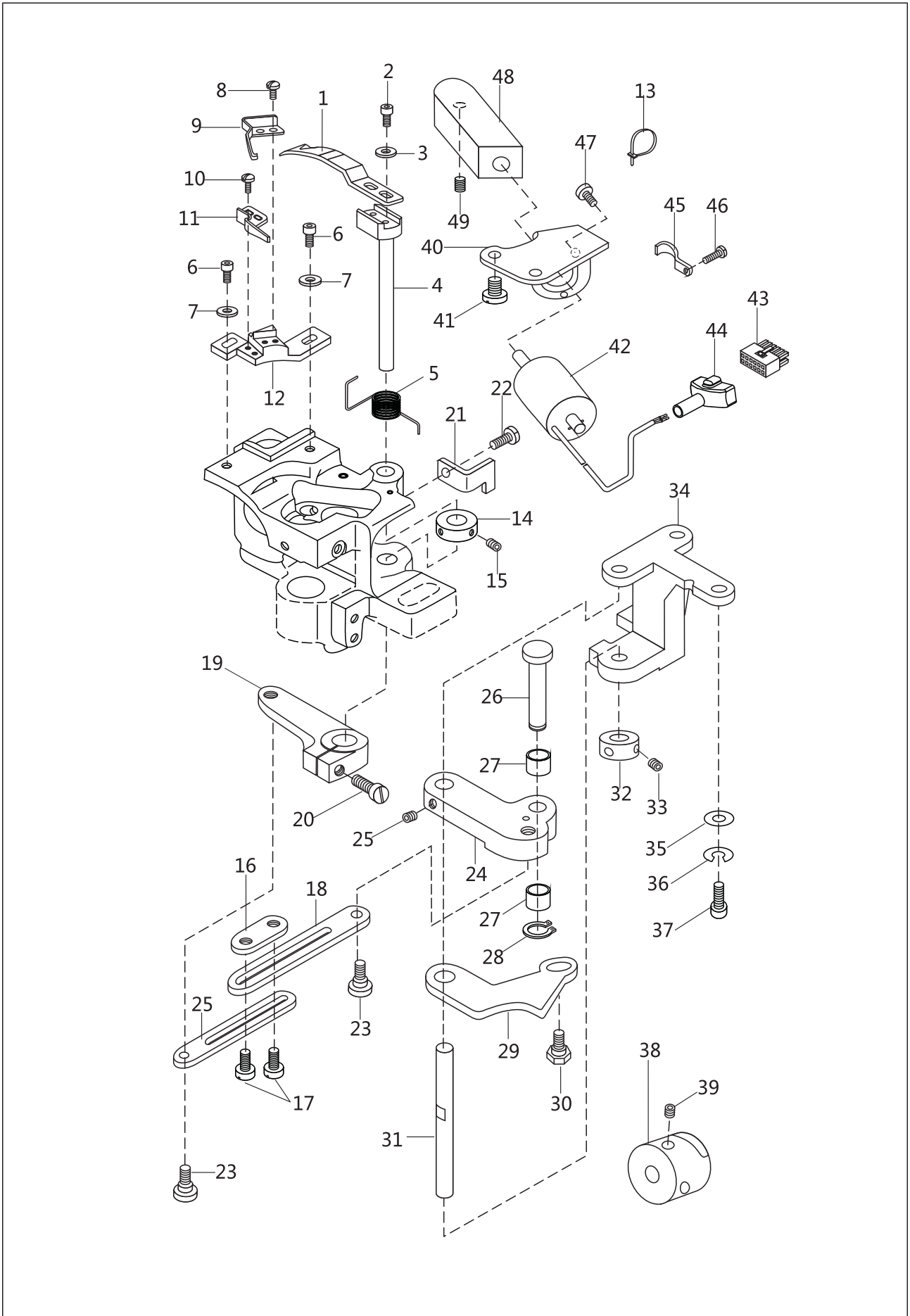

9. Thread trimming mechanism

No.	Part Number	Name	Qt.	Remark
1	228WF4-026	Movable knife	1	
2	228WF4-027	Screw	2	M3×8
3		Washer	2	GB/T97.1 3
4	228WF4-025	Movable knife driven shaft	1	
5	228WF4-028	Spring	1	
6	228WF4-035	Screw	2	SM11/64"×40
7		Washer	2	GB/T95 4
8	13WF2-062	Screw	2	SM3/32"×56
9	228WF4-032	Spring plate	1	
10	13WF2-062	Screw	2	SM3/32"×56
11	228WF4-030	Fixed knife	1	
12	228WF4-034	Fixed knife bracket(R)	1	
13	2KT5-001a	Band	1	
14	228WF4-029	Collar	1	
15	36WF5-021	Screw	2	SM11/64"×40
16	228WF4-016	Lock plate	1	
17	228WF4-017	Screw	2	SM11/64"×40
18	228WF4-014	Link	2	
19	228WF4-022	Crank	1	
20	41WF3-018	Screw	1	SM3/16"×28
21	228WF4-024	Stop plate	1	
22	1WF5-042	Screw	1	SM11/64"×40
23	228WF4-015	Screw	2	
24	228WF4-010	Crank	1	
25	36WF5-025	Screw	2	SM11/64"×40
26	228WF4-011	Pin shaft	1	
27	228WF4-012	Roller	2	
28		Retaining ring	1	GB896 3.5
29	228WF4-008	Driven link	1	
30	228WF4-009	Screw	1	
31	228WF4-006	Shaft	1	
32	228WF4-007	Collar	1	
33	36WF5-025	Screw	2	SM11/64"×40
34	228WF4-005	Bracket	1	
35	17WF4-012	Washer	2	
36		Spring washer	2	GB93 6
37	60WF4-003	Screw	2	SM15/64"×28
38	228WF4-013	Trimming cam	1	
39	2KT5-027	Screw	2	SM1/4"×40

9. Thread trimming mechanism

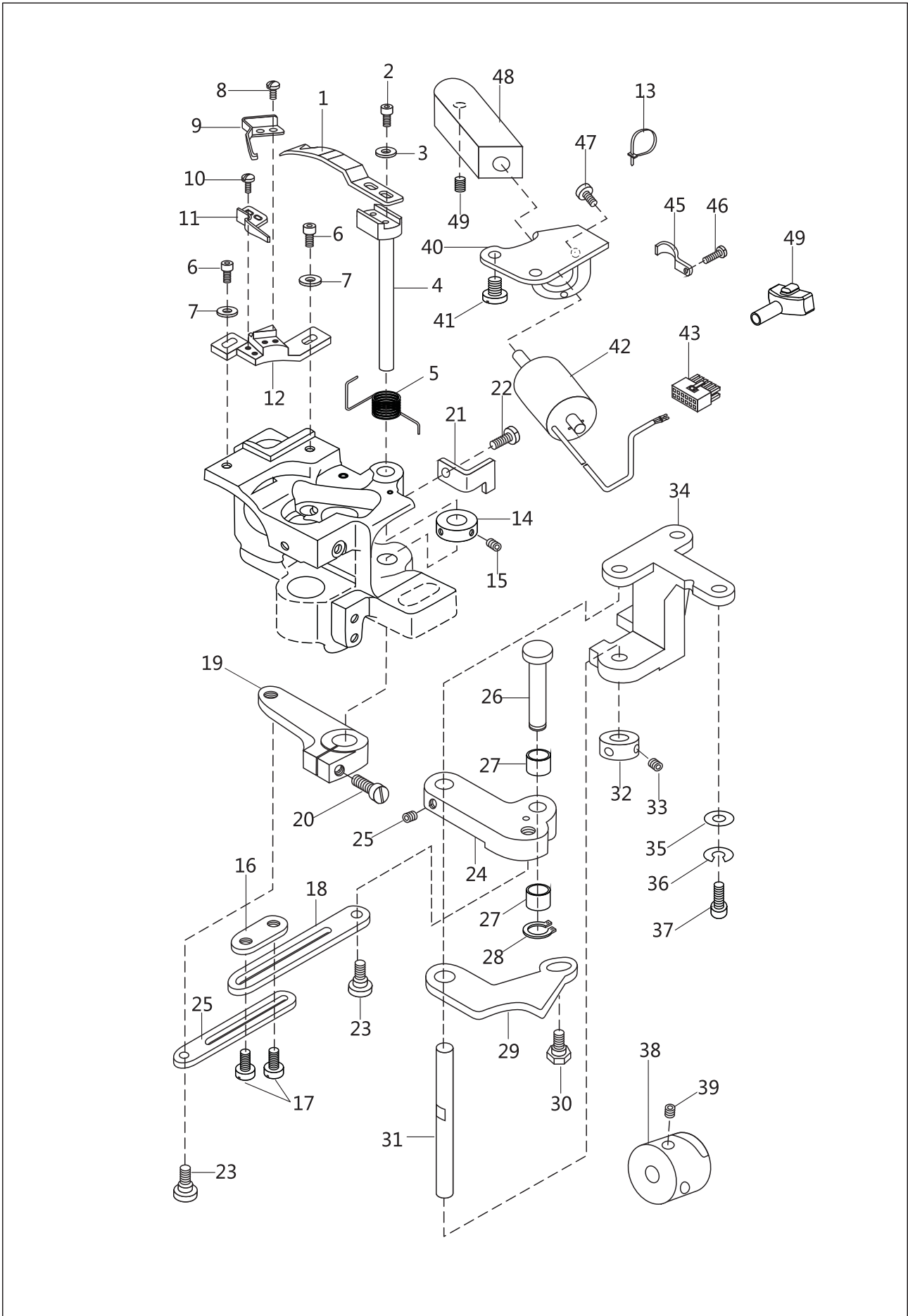

9. Thread trimming mechanism

No.	Part Number	Name	Qt.	Remark
40	228WF4-001	Solenoid installing bracket	1	
41	13WF2-045	Screw	2	SM15/64"×28
42	228WF4-002	Trimming solenoid	1	
43	356WF4-002	Joint	1	
44	356WF4-003	Cover	1	RAL7015
45	228WF4-003	Wire clamp	1	
46	52WF2-030	Screw	1	SM11/64"×40
47	18WF3-021	Screw	2	M4×8
48	228WF4-004	Link block	1	
49	21WF1-060	Screw	2	SM11/64"40

10.Auto-reverse feed mechanism

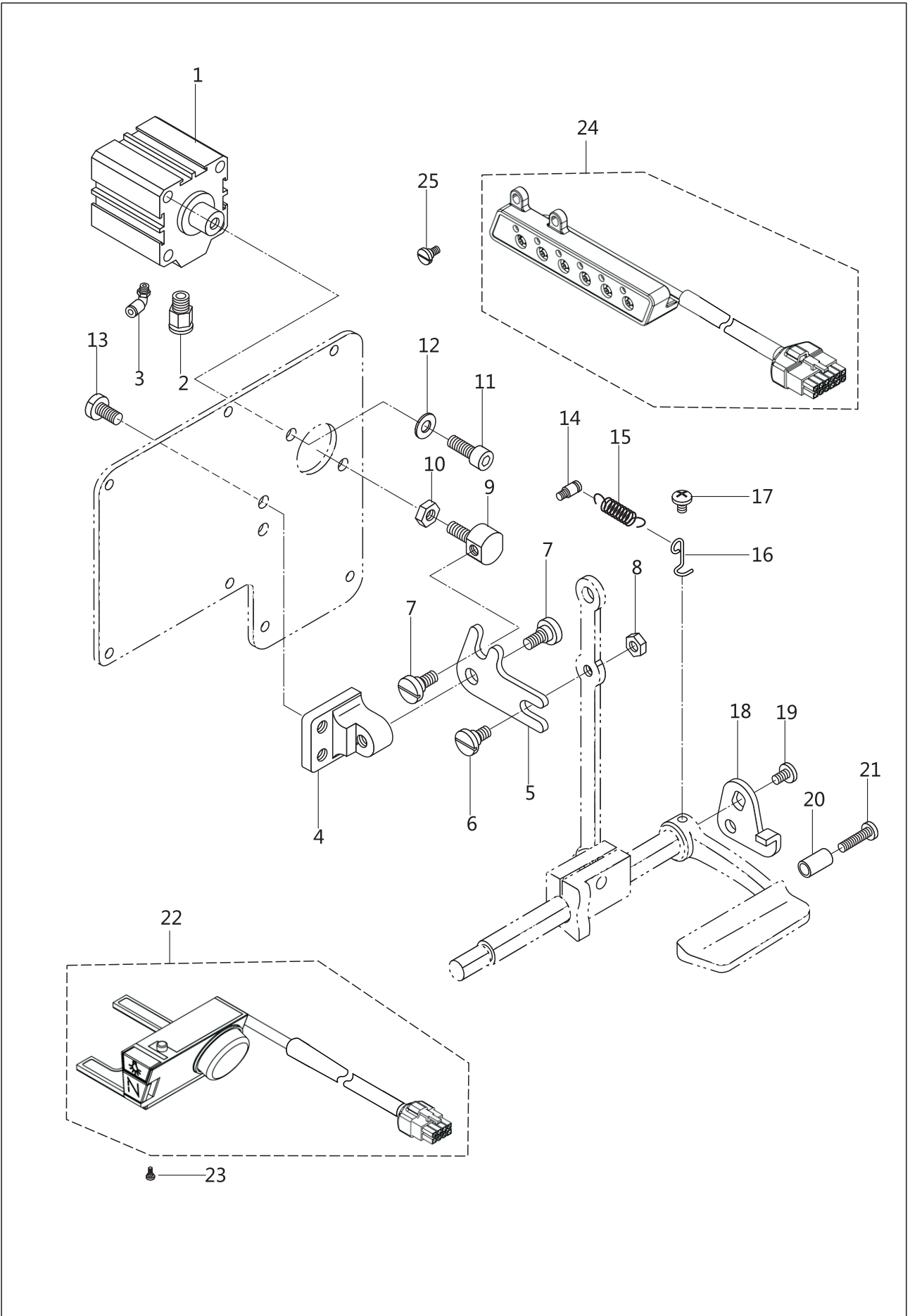

10.Auto-reverse feed mechanism

No.	Part Number	Name	Qt.	Remark
1	119WF8-001A	Cylinder	1	
2	385WF3-002	Joint	1	
3	119WF8-001B	Silencer	1	
4	119WF8-004	Bracket	1	
5	119WF8-005	Driven lever	1	
6	119WF8-003	Screw	1	
7	119WF8-006	Screw	2	SM15/64 " ×28
8	22WF3-004	Nut	1	
9	119WF8-002	Joint	1	
10	22T5-011A7	Nut	1	
11	52WF5-003	Screw	4	M6×14
12	72WF2-010	Washer	4	
13	36WF1-056	Screw	2	
14	119WF8-011	Screw bar	1	
15	119WF8-008	Spring	1	
16	119WF8-009	Hook	1	
17	119WF8-010	Screw	1	
18	119WF8-007	Stop plate	1	
19	22T5-010D3	Screw	1	
20	119WF8-012	Block	1	
21	36WF4-027	Screw	1	
22	385WF4-001	Reverse sewing switch assy.	1	
23	13WF1-015	Screw	2	M3×6.5
24	385WF4-002	Manual switch assy.	1	
25	1WF1-016	Screw	2	SM11/64 " ×40

11.Auto-lifer mechanism

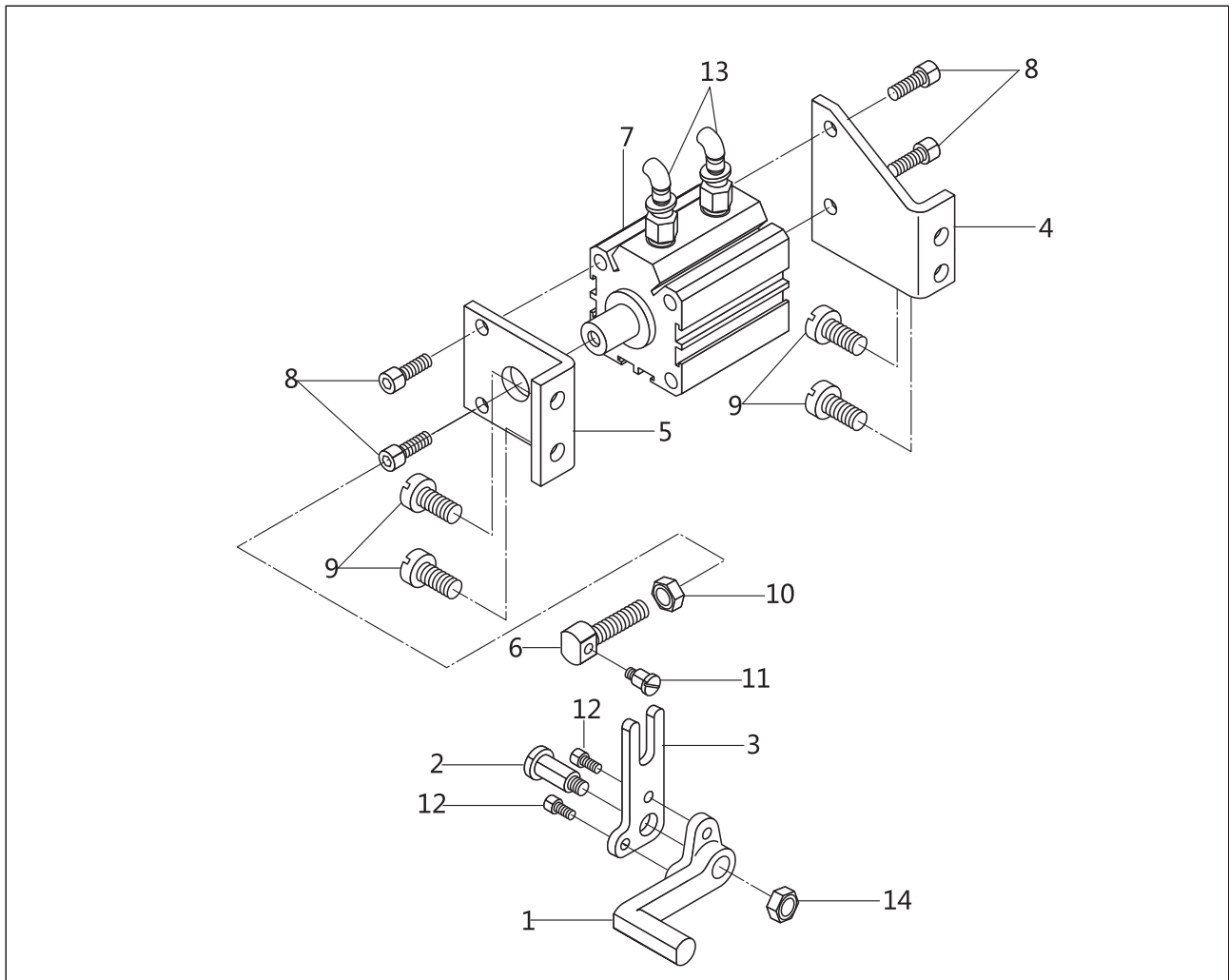

No.	Part Number	Name	Qt.	Remark
1	228WF5-001	Crank	1	
2	228WF5-002	Screw	1	
3	228WF5-003	Driven lever	1	
4	228WF5-004	Cylinder support(1)	1	
5	228WF5-005	Cylinder support(2)	1	
6	228WF5-006	Connector	1	
7	228WF5-008	Cylinder	1	
8	7KT1-003	Screw	4	M6×20
9	13WF2-045	Screw	4	SM15/64"×28
10		Nut	1	GB/T6170 M8
11	228WF5-007	Screw	1	
12	13WF6-010	Screw	2	M5×10
13	385WF3-002	Joint	2	PL04-001
14	6K5-005	Nut	1	SM5/16"×24

12.Climbing device mechanism

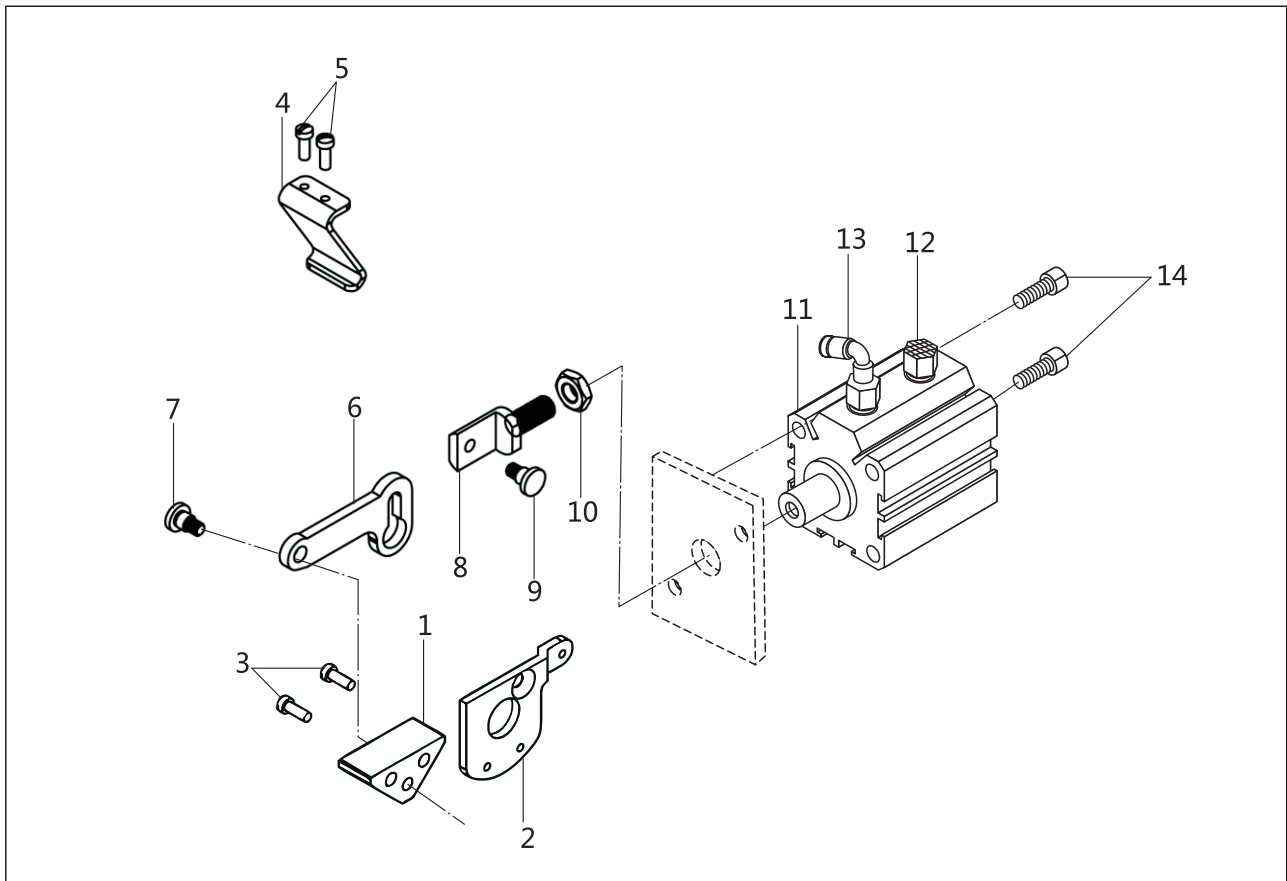

No.	Part Number	Name	Qt.	Remark
1	259WF-010	Crank	1	
2	259WF-011	Plate	1	
3	36WF4-027	Screw	2	SM15/64"×40
4	259WF-014	Stopper	1	
5	6K1-057	Screw	2	SM15/64"×40
6	259WF-009	Lever	1	
7	259WF-015	Screw	1	
8	259WF-012	Bracket	1	
9	259WF-016	Screw	1	
10		Nut	1	GB/T 41 M8
11	93WF23-001	Cylinder	1	
12	119WF8-001B	Silencer	1	
13	385WF3-002	Joint	1	
14		Screw	2	GB/T 70.1 M5 L=45

13.Lubrication components

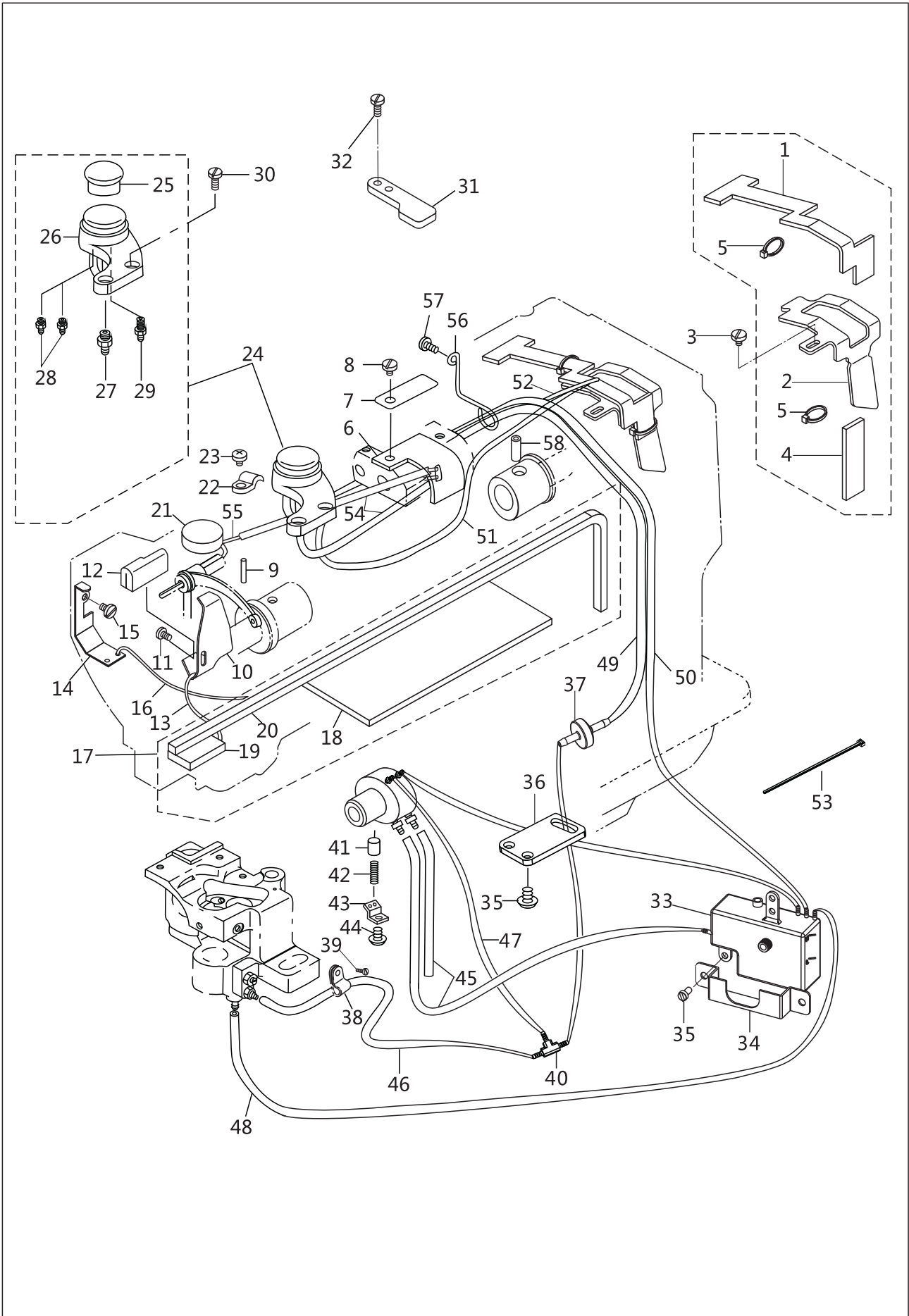

13.Lubrication components

No.	Part Number	Name	Qt.	Remark
1	92WF5-001	Oil felt	1	SM11/64"×40
2	92WF5-002	Bracket	1	
3	1WF1-011	Screw	1	
4	92WF5-003	Oil felt	1	
5	2KT7-001A	Band	2	
6	119WF5-003	Oil felt	1	
7	119WF5-001	Plate	1	
8	13WF2-014	Screw	1	
9	92WF5-010	Oil felt	1	
10	92WF5-011	Oil shield	1	
11	16WF1-059	Screw	1	SM9/64"×40
12	92WF5-012	Oil felt	1	Φ2×250
13		Oil wick	1	
14	92WF5-013	Oil shield	1	
15	36WF1-031D	Screw	1	SM11/64"×40
16		Oil wick	1	Φ2×250
17	312WF5-001	Oil felt assy.	1	
18	92WF5-014A	Felt	1	
19	92WF5-014B	Felt	1	
20	312WF5-001A	Oil wick	1	
21	92WF5-009	Felt	1	
22	1WF6-036	Band	1	SM11/64"×40
23	17WF1-020	Screw	1	
24	199WF6-001C	Oil box assy.	1	
25	199WF6-001A	Oil window	1	
26	199WF6-001C1	Oil box	1	
27	199WF6-002	Connector	1	SM11/64"×40
28	199WF1-048	Connector	2	
29	199WF1-048	Connector	1	
30	1WF5-042	Screw	2	
31	92WF5-004	Plate	1	
32	W01111	Screw	2	SM15/64"×28
33	228WF2-007	Oil box	1	SM15/64"×28
34	228WF2-008	Supporter	1	
35	13WF2-045	Screw	3	
36	199WF6-004	Supporter	1	
37	199WF6-023	None-return valve	1	
38	80WF5-014	Pipe clamp	1	

13.Lubrication components

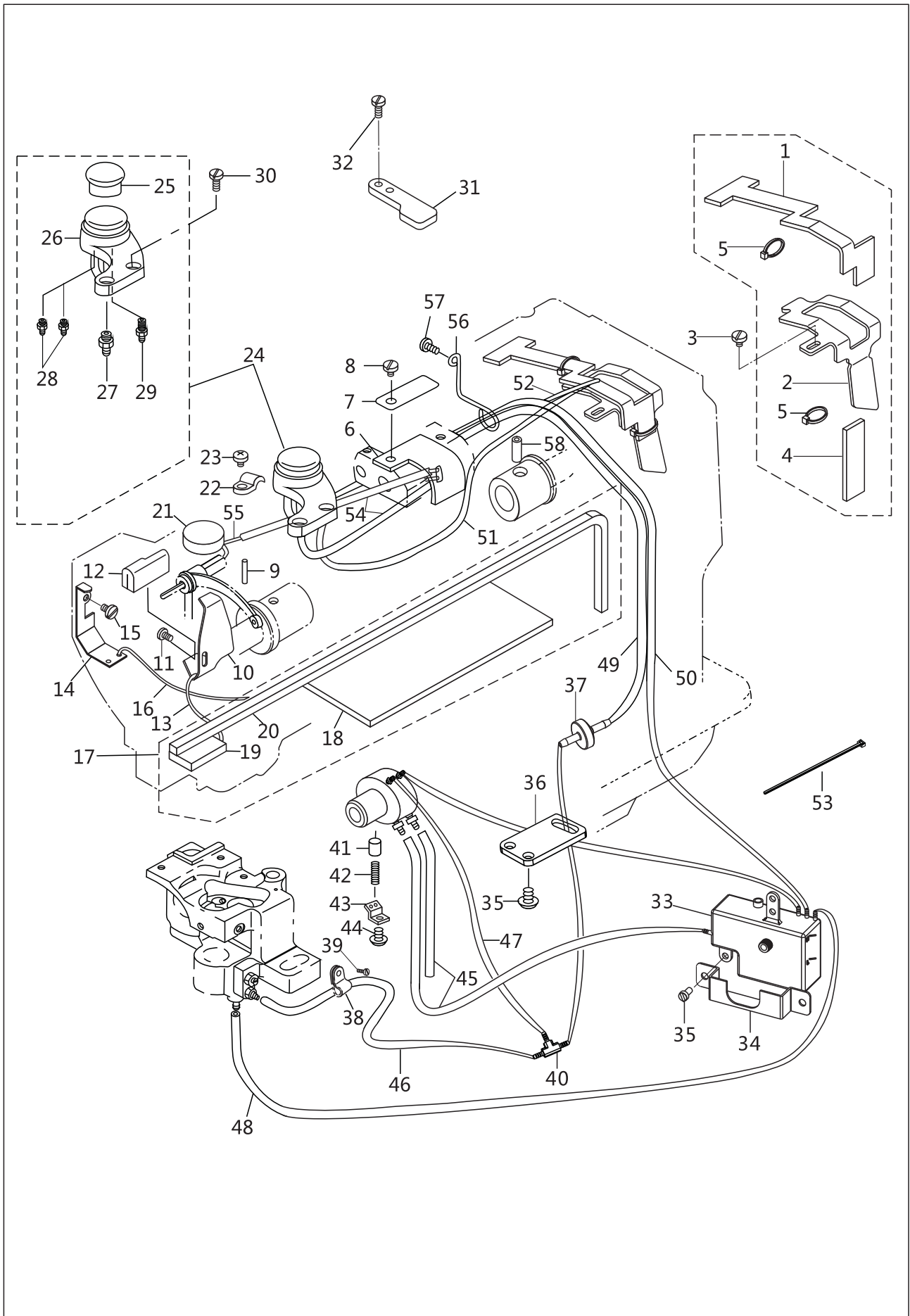

13.Lubrication components

No.	Part Number	Name	Qt.	Remark
39	1WF1-011	Screw	1	SM11/64"×40
40	199WF6-006	Triplet nozzle	1	
41	199WF6-007	Trunk piston	2	
42	199WF6-008	Spring	2	
43	199WF1-058	Plate	1	
44	1WF6-026	Screw	1	SM11/64"×40
45	199WF6-010	Oil tube	2	Φ5×1 370
46	312WF5-002	Oil tube	1	Φ5×1 325
47	199WF6-011	Oil tube	1	Φ5×1 80
48	312WF5-003	Oil tube	1	Φ5×1 405
49	312WF5-004	Oil tube	1	Φ5×1 715
50	312WF5-005	Oil tube	1	Φ5×1 605
51	199WF6-016	Oil tube	1	Φ5×1 200
52	199WF6-019	Oil wick	1	Φ5×450
53	2KT5-001A	Band	11	
54	199WF6-018	Oil tube	1	Φ5×1 225
55	199WF6-019	Oil wick	1	Φ5×480
56	199WF6-020	Setting hook	1	
57	36WF4-017	Screw	1	
58	33T4-004	Oil tube	1	

14. Accessories

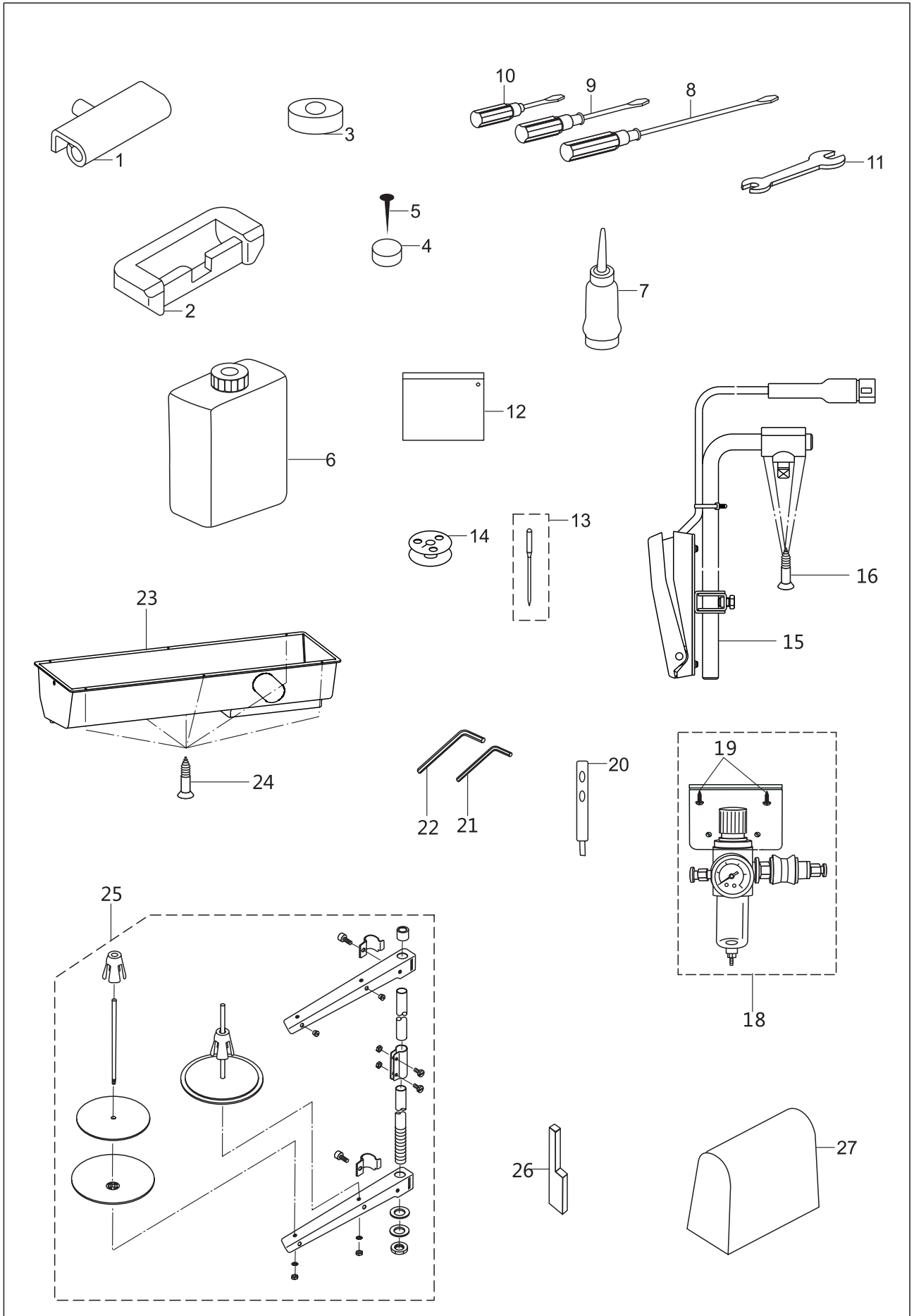

14. Accessories

No.	Part Number	Name	Qt.	Remark
1	22T9-007F1	Machine hinge	2	
2	22T9-007F2	Hinge cushion	2	
3	92WF6-025	Corner cushion	4	
4	92WF6-026	Felt	4	
5		Pin	6	SG162 19
6	1F-012	Oil tank	1	
7	33TF-011	Oil pot	1	
8	33TF-012	Screwdriver (big)	1	
9	33TF-013	Screwdriver (middle)	1	
10	33TF-014	Screwdriver (small)	1	
11	92WF6-028	Wrench	1	
12	33TF-010	Parts bag	1	
13		Needle	10	DPX17 23#
14	228WF1-011	Bobbin	3	
15	200WF21-001	Knee switch	1	
16		Screw	4	GB 846 ST4.2X16
18	177WF10-006	Air filter assy.	1	
19		Screw	2	GB 845 ST4.2X16
20	92WF2-037	Thread guider pin	1	
21		Inner hexagon spanner	1	S=2
22		Inner hexagon spanner	1	S=3
23	394WF24-008	Oil pan	1	
24		Screw	6	GB 846 ST4.2X16
25	14F0-00	Thread stand	1	
26	228WF6-001	Fixed knife installation gauge	1	
27		Machine head cover	1	83X40

INSTRUCTION MANUAL

YSC-8361 AC Servo System

Please read this manual before using the Controller

Please keep this manual within convenience access for easy reference

Version: V.1.00

For your perfect operation and safety, before using your new machine, please read this instruction manual.

YSC-8561 controller is used for an industrial sewing machine. With industrial sewing machine, it is normal to carry out work while positioned directly in front of moving parts such as the needle and thread take-up, and consequently there is always a danger of injury that can be caused by these parts. So when you ready to operate the machine, please follow the instructions from trained personnel and instructors regarding safe and correct operation.

1. NOTICE

1.1 Work environment

- ▲ Please use 220V AC in $\pm 10\%$ ranges.
- ▲ To avoid the false operate, please keep the product away from the high electromagnetic interference.
- ▲ Please operate in the area which temperature is $5\text{ }^{\circ}\text{C} \sim 45\text{ }^{\circ}\text{C}$ and humidity is 80% or less.













1.2 Notice of installation





- ▲ Turn off the power and unplug the cord before installation.
- ▲ The wire must not set to be near the wheel and other movable parts.
- ▲ To avoid the static interference and current leakage, all grounding must be done.

1.3 Notice of safety

- ▲ Turn off the power before maintenance and repairs or raising the machine arms, or changing needle, or threading needle.
- ▲ Please don't open the box except the professional.
- ▲ When turn on the machine in the first time, use low speed to operate and check the correct rotation direction.
- ▲ During machine operation, don't touch any moving parts.
- ▲ All moving parts must use the protective device to avoid the body contact and objects insertion.
- ▲ When there is water or other liquid, or caustic material on box or motor, you must stop operation and turn off the power.
- ▲ All connector shouldn't be plug and unplug when power on.
- ▲ The connector should be plug and unplug in the correct method.

2. OPERATING FIELD P200B

Start backtack		Single start tacking, A is the stitches of forth sewing; B is the stitches of back sewing. They are both in range 1~15
		Double start tacking, A is the stitches of forth sewing; B is the stitches of back sewing. They are both in range 1~15.
End backtack		Single end tacking, C is the stitches of back sewing; D is the stitches of forth sewing. They are both in range 1~15
		Double end tacking, C is the stitches of back sewing; D is the stitches of forth sewing. They are both in range 1~15
Free Sewing		<p>▲ As the pedal is stepped forward, the starttacking(if selected) will be done automatically, then machine will start normal sewing. Once the pedal returned to balance, machine will stop immediately.</p> <p>▲ As the pedal stepped backward, the end tacking, trimming and wiping(if selected) will be done automatically</p>
Constant-Stitch		<p>▲ Once the pedal is stepped forward, F, G stitches will be completed with E times.</p> <p>▲ Constant-Stitch Sewing will perform the number of segments and times as setting, when the stitches are zero, machine will stop immediately.</p>
Bar-Tacking Sewing		<p>▲ Once the pedal is stepped forward, all the seams of bar tacking, A, B, C, D sections will be completed with E times, and the trimming will be done automatically.</p> <p>▲ The pedal must be returned to balance for next sewing.</p>
Lower thread Counter		Enter lower thread counter interface
Soft start		Enable or disable the soft start
Needle Up / Needle Down		Select the stop position of needle bar
Trimming Enable		Enable or disable the trimming
Interface Selection		Switch current interface to another
One-Key Default /Lock keys		<p>▲ Sewing interface: lock the keypad</p> <p>▲ Parameter interface: restore a parameter to default</p>

Parameter Function		Enter or exit parameter function interface
Save		Confirm and save current value of parameter
Add		Value increase
Sub		Value decrease

3. OPERATING ELEMENTS

3.1 Single start back-tacking setting

- A Stitches = 0
Seven-segment display A display 『-』 .
Sewing process: B stitches back – normal sewing.
- A Stitches ≠ 0
Sewing process: A stitches forth – B stitches back – normal sewing

3.2 Double start back-tacking setting

- A Stitches = 0
Sewing process: B stitches back – B stitches forth – B stitches back – normal sewing.
- A Stitches ≠ 0
Sewing process: A stitches forth – B stitches back – A stitches forth – B stitches back – normal sewing

3.3 Single end back-tacking setting



- A Stitches = 0
Seven-segment display D display 『-』 .
Sewing process: C stitches back – end.
- A Stitches ≠ 0
Sewing process: C stitches back – D stitches forth – end.



3.4 Double end back-tacking setting

- A Stitches = 0
Sewing process: C stitches back – C stitches forth – C stitches back – end.
- A Stitches ≠ 0
Sewing process: C stitches back – D stitches forth – C stitches back – D stitches forth – end.

3.5 Lower thread counter



Set A11 to "1" to active the counter.

- Enter interface:** Press  Or Special function interface SN F6(refer to 6.6).
- Initialize the counter:** Press , the initial value of the lower thread counter which was set previously will be shown. Adjust it to a suitable value.
- How the counter works:**
 - Display initial value

- ☒ The counter reduces by 1 for every 10 stitches sewn.
- ☒ If the counter less than 1, the display area twinkled and buzzer sounds for 3 times. The machine will not start up again. Press  the warning will disappear and sewing will be possible, the counter reduces continue.
- ☒ Press  again, the display will return to the initial value

3.6 Product quantity counter

Set A11 to "1" to activate the counter.

- ☒ **Enter interface:** Special function interface SN F2, refer to 6.2
- ☒ **Data acquisition:** In SN F2 interface, press  will be into collect process interface, seven-segment display D displays 『L』, seven-segment displays E,F,G will display the number of stitches for this process. It records the number of stitches and the number of trimmer. Press  to save the data and return SN F2 interface.
- ☒ **How the Counter works:** If sewn the number stitches more than the number of stitches collected 90%, and the number of trimming times more than collected, the counter add 1.
- ☒ **Clear Counter:** press 

3.7 Adjust the backtack

- ☒ Adjusting of RVE.SOL action time

For start/end backtack or bar tacking, if unbalanced situation is appeared during natural direction to reverse direction, please correct it as below:

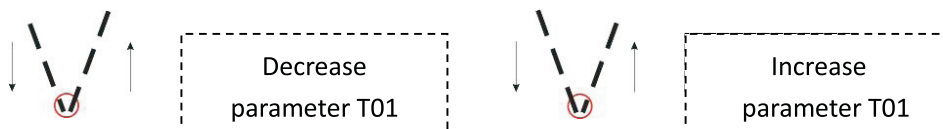

- ☒ Adjusting of RVE.SOL release time



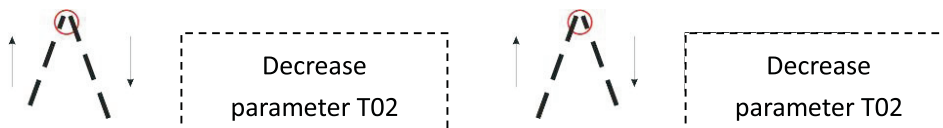



For start/end tacking or bar tacking, if unbalanced situation is appeared during reverse direction to natural direction, please correct it as below:



3.8 Quick functions on the keypad



Figure 1: Keypad on the machine arm

Foot stroke		Toggle foot stroke level
Start and end strips		This key cancels the general setting for sewing start and end strips. If strips are activated, pressing the key disables the next strip. If no strips are activated pressing the key sews the next strip.
Position of the needle		If the key is selected the needle moves to a specific position. This position is determined individually via the parameter settings, more information read D15, D16
Stitch Length		If this key is selected, the machine sews using the smaller stitch length selected at lower adjusting wheel for the stitch length
Additional thread tension		This key switches on the additional thread tension
Pause		If the pause switch is triggered, all functions are locked except parameters, the adjacent led light up, panel display "PAUSE"

3.9 Lock the hot keys and keypad

if  key is triggered, all functions on the keypad and hot keys are invalid.

3.10 Electronic hand wheel

The value of "A23" is 1, electronic hand wheel is activated. By turning the hand wheel, you can move the needle bar forwards or backwards.

3.11 Hot keys

Pressing the Reverse switch:

Default: Reverse.

Refer to Parameter list, A04.

Pressing the hand wheel:

Default: None

Refer to Parameter list, A05.

3.12 Quick stroke adjustment via knee switch

On machines with quick stroke adjustment activated via a knee switch, the elevated sewing foot stroke is switched via the knee switch.

4. OPERATION OF THE SPECIAL FUNCTION INTERFACE

Press  could be access special function interface from normal function interface, showed as below:

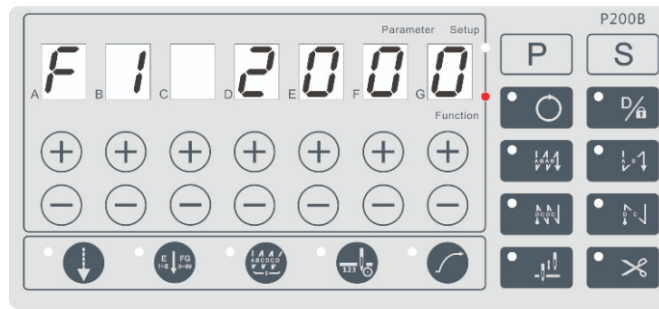

Figure 2: Function Interface

Bar A and B according to SN of function, bar D~G display contents, press **B+** and **B-** to select function:

4.1 Dynamic speed limitation

SN F1: display current speed up limitation, could be change during running.

4.2 Product quantity counter

SN F2: display the product quantity

4.3 Machine degree

SN F3: display the machine degree.

4.4 Torque enhancement function at low speed

SN F4: display D: press **D+** and **D-** to open/close the function.

Display F,G: 0~10, the gear.

4.5 Actual speed display

SN F5: display the actual speed.

4.6 Lower thread counter

SN F6: display how much the lower thread is remaining

5. PARAMETER INSTRUCTION

5.1 Setting parameter

Press to enter Parameter Interface.

Seven-Segment display E display the parameter type, press "**E+**" and "**E-**" key to change it.

Seven-Segment display F, G display the parameter index, press "**F+**", "**F-**", "**G+**", "**G-**" key to change it.

Seven-Segment displays A, B, C, D display the parameter value, press the keys under them to change it.

For example, Graph4: parameter index is 1, type is P, value of "S01" is 2000, the nixie tube will blink when change the value. Press to confirm, press to cancel and return to sewing interface.

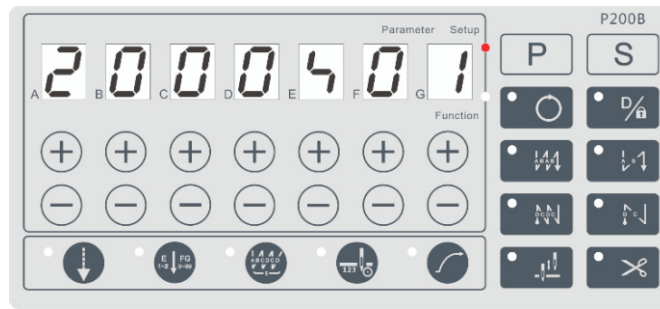

Figure 3: Parameter Interface

5.2 Get the permission of setting O type parameter

Only S, T and A type parameter can be select normally, if you want to change the O type parameter, you must power on while press **P** key, when you see 『DO EN』, you get the permission successfully.

5.3 Parameter solidifying

If users want to change some parameter's default value, then select the parameter, press **○** maintain a moment, after 『SD OK』 displaying, the default value has been changed.

5.4 Restore parameter through one-key default

Select any parameter in parameter interface, **D/A** default value. The bar will be twinkling if modified, use **S** to confirm or **P** repeal change

5.5 Controller recovery

- Resume the default value of all parameters**
Set parameter **O17** to "ON", turn on the power again, after twinkling of "INIT" finished, all parameters have been default value themselves
- Restore Factory Defaults**
Set parameter **O51** to "ON", turn on the power again.

5.6 Abate safety switch

If you want to abate the function of Safe SW., you can change the value of "**O31**" from "1" to "0" normally, in a particular case, for example, the Safe SW. broke down, you can power on while press "**C+**" key to abate the function of Safe SW.

warning: it means potential security problems for you if you abate the function of Safe SW., so attention please.

5.7 General parameter table

SN	RANGE	DESCRIPTION
S type Parameter		
S01	500~3500spm	Maximum sewing speed
S02	150~500spm	Minimum sewing speed
S03	500~2000spm	Speed adjustment for start back-tacking

S04	500~2000spm	Speed adjustment for end back-tacking
S05	500~2000spm	Speed adjustment for bar-Tacking
S06	500~2000spm	Speed adjustment for constant-stitch sewing
S07	150~300spm	Speed adjustment for trimmer
S08	200~500spm	Soft start speed
S09	500~3500spm	Speed adjustment for foot stroke gear 1
S10	500~3500spm	Speed adjustment for foot stroke gear 2
S11	500~3500spm	Speed adjustment for foot stroke gear 3
S12	500~3500spm	Speed adjustment for foot stroke gear 4
S13	500~3500spm	Speed adjustment for foot stroke gear 5
S14	500~3500spm	Speed adjustment for foot stroke gear 6
S15	500~3500spm	Speed adjustment for min-foot stroke
S16	50~500spm	Speed adjustment for pull back after trim
T type Parameter		
T01	1~200(millisecond)	Action time of the REV SOL.
T02	1~200(millisecond)	Release time of the REV SOL.
T05	1~500(millisecond)	Foot lifer-Delay time adjustment for pedal's feet lift position
T06	1~500(millisecond)	Running delay time adjustment for Automatic Foot Lifer
T09	1~1000(millisecond)	Safety switch-Delay time adjustment for machine vibration
T10	1~200(millisecond)	Pedal-Delay time adjustment for pedal vibration
T11	1~1000(millisecond)	Delay time adjustment when A20/A22 set as 1
A type Parameter		
A01	0~1	Needle positions 1 = Up Position 0 = Down Position
A02	0~1	Automatic Constant-Stitch sewing 1 = On 0 = Off
A03	0~1	Correction stop mode 1 = stop position accord to D15, D16 0 = random
A04	0~13	Function selection of reverse switch 0 = none 1 = reverse 2 = half stitch correction 3 = continuously correction 4 = half stitch correction at machine stop, reverse at machine run 5 = continuously correction at machine stop, reverse at machine run

		6 = none 7 = trim at normal sewing, foot lifer after trimming 8 = foot lifer 9 = foot stroke 10 = single backtack supression 11 = 2 nd STITCH LENGTH 12 = additional thread tension 13 = thread mode
A05	0~13	Function selection of hand wheel switch, refer to A04
A06	0~1	Trim selection 1 = trimmer valid 0 = trimmer invalid
A07	0~1	Lock machine buttons selection (machine buttons includes Hot Keys, Hand Wheel Switch, Reverse Switch) 0: machine buttons work 1: machine buttons not work
A09	0~1	Foot lift selection 1: Foot lifer function valid 0: Foot lifer function invalid
A10	0~1	Clamp selection 1: Clamp valid 0: Clamp invalid
A11	0~1	Product Quantity Counter 1 = On 0 = Off
A12	0~1	Lower thread Counter 1 = On 0 = Off
A13	0~1	Pull Back after Trim (angle refer to O35) 1 = On 0 = Off
A14	0~1	Automatic Foot Lifer when stopped 1 = ON 0 – Off
A15	0~1	Automatic Foot Lifer after trimming 1 = On 0 = Off
A16	0~1	Automatic constant-stitch sewing after start backtacking (only when A02=0) 1 = On 0 = Off
A17	0~1	Automatic end backtacking for constant-stitch sewing (only when A02=0)

		1 = On 0 = Off
A18	0~1	Upper position when switch on the control 1 = On 0 = Off
A19	0~2	Function when Half-Heeling the pedal 2: thread cutting 1: foot lift 0: Balance
A20	0~1	Mode of start backtack 1: stitch for stitch 0: normal
A22	0~1	Mode of end backtack 1: stitch for stitch 0: normal
A23	0~1	Electronic handwheel 1 = On 0 = Off
A27	0~3	Mode of thread tension and thread tension reduction when sewing foot lift is active 0 = no thread tension lift 1 = thread tension lift in the seam 2 = thread tension lift after trimming 3 = thread tension lift in the seam and after trimming
A28	0~1	Automatic release additional thread tension when push the knee switch 1 = ON 2 = Off
D type Parameter		
D01	0~359(°)	Angle of needle bar up lever
D02	0~359(°)	Angle of needle bar down lever
D03	0~359(°)	Switch-on angle of Trimmer
D04	0~359(°)	Switch-off angle of Trimmer
D05	0~359(°)	Switch-on angle of Reverse SOL.
D06	0~359(°)	Switch-off angle of Reverse SOL.
D07	0~359(°)	Switch-on angle of thread clamp
D08	0~359(°)	Switch-off angle of thread clamp
D13	0~359(°)	Switch-on angle of thread tension
D14	0~359(°)	Switch-off angle of thread tension
D15	0~359(°)	Correction angle 1
D16	0~359(°)	Correction angle 2
O type Parameter		
O01	1~10(stitch)	Number of soft start stitches

O04	1~1000(millisecond)	Delay time for stitch for stitch backtrack. Refer to A20
O06	0~1	Automatic foot lifter release 1 = Automatic foot lifter release after the time of O07 0 = always hold
O07	5~30(second)	Refer to O06
O17	0~1	Refer to 5.5
O23	1~60(second)	The running time of aging test
O24	1~60(second)	The idle time of aging test
O25	1~720(hour)	The total time of aging test
O26	0~2	Set to "1/2" active the aging test
O31	0~1	Safety switch function 1 = open 0 = close
O32	0~1	Polarity of safety switch 0 = Normal closed 1 = Normal opened
O35	0~359	Angle of pull back after trimming
O48	0~100	The duty of clamp SOL
O51	0~1	Refer to 5.5
O56	0~4095	Pedal input MAX value: value \geq O57
O57	0~4095	Pedal input dividing value of high speed and low speed: O56 \geq value \geq O58
O58	0~4095	Pedal input dividing value of low speed and Balance: O57 \geq value \geq O59
O59	0~4095	Pedal input dividing value of Balance and Foot lifter: O58 \geq value \geq O60
O60	0~4095	Pedal input dividing value of Foot lifter and Trimming: O59 \geq value \geq O61
O61	0~4095	Pedal input MIN value: value \leq O60
O63	0~5	Pedal mode 0 = linear 1 = polyline 2 = curve(slow \rightarrow quick) 3 = curve(quick \rightarrow slow); 4 = S curve(slow \rightarrow quick \rightarrow slow) 5 = S curve(quick \rightarrow slow \rightarrow quick)
O64	500~5000	The speed of turning point when O63 set as 1
O65	0~4095	The value of turning point: O56 \geq value \geq O57
O68	0~1	Mode of the End Backtack 0 = Stop first, then act RVS SOL; 1 = Act RVS SOL when running
O69	0~1	Correction mode 0 = only the machine stopped

		1 = before trimming
O83	0~720	Step width for electronic hand wheel
O84	0~200	Speed for electronic hand wheel

6. HOW TO ADJUST the ZERO OF THE MACHINE

Press hold  and turn on the power to access to adjust ZERO for the machine.

Press  to confirm and save.

7. ERROE MESSAGES & POSSIBLE TROUBLESHOOTING

ERROE CODE	DESCRIPTION	SOLUTION
PEDAL	Pedal warning	<ul style="list-style-type: none"> - Check or replace the pedal - Pedal not connected - Do not pedal yet
CARE	Safe Switch problem	<ul style="list-style-type: none"> - Check the Safe Switch - Replace the safe switch
KEY1	Machine button warning	<ul style="list-style-type: none"> - Do not press machine button - Replace the buttons
E101	High AC voltage fault	<ul style="list-style-type: none"> - Check mains voltage - Stabilize mains voltage - Use generator
E103	High Bus voltage fault	<ul style="list-style-type: none"> - Check mains voltage - Stabilize mains voltage - Use generator
E106	Bus current overload	<ul style="list-style-type: none"> - Check the encoder and motor - Replace the encoder - Replace the motor
E107	Motor blocked	<ul style="list-style-type: none"> - Eliminate stiff movement in the machine - Replace the encoder - Replace the motor
E110	Encoder/Synchronizer fault	<ul style="list-style-type: none"> - check or replace the synchronizer for a belt-drive machine - check or replace the encoder for a direct-drive machine
E190, E290	Software Update Error	<ul style="list-style-type: none"> - Software update - Replace the control
E191, E291	Software Update Error	<ul style="list-style-type: none"> - Software update - Replace the control
E193, E293	Software Update Error	<ul style="list-style-type: none"> - Software update - Replace the control
E294	Software Update	<ul style="list-style-type: none"> - Software update

	Communication Error	- Replace the control
E199	Software Update Error	- Software update - Replace the control
E900	Communication problem	- Restart the control - Replace the control

8. Controller Check

Press hold **S** during power on, it will display "TEST" and then enter the Check interface. Seven-Segment display A display check index, the else display contents.

8.1 Pedal

Display B,C shows the pedal position status, display D,E,F,G display sample value.

<i>bL</i>	Balance position
<i>L4</i>	Low-speed position, is stepping on the first paragraph
<i>H4</i>	High-speed position, is stepping on the second paragraph
<i>FP</i>	Foot position, anti-step on the first paragraph
<i>rA</i>	Trim position, anti-step on the second paragraph
<i>E-</i>	Not connected or the pedal is faulty

8.2 Synchronizer

Synchronizer: turning the motor, display C value changes from 0 to 1

Position encoder: turning the motor, display D E,F,G value changes between 0 to 720.

8.3 Keypad Test

Display B, C, D, E, F, G correspond to the six keys on keypad, when press the key,

the corresponding display will change from 0 to 1, press **+** to light on the

corresponding LED, press **-** to light off, **S** to light on all and **P** to light off all, the correspondence between the digital tube and the function key is as follows

Display B: foot stroke

Display C: start and end trips

Display D: position of the needle

Display E: stitch length

Display F: additional thread tension

Display G: pause

8.4 Motor encoder

8.5 Output Device

Digital F, G shows the current test solenoid type, the corresponding relationship is as follows

Solenoid	Display
Trimmer	<i>r-</i>
Foot	<i>F0</i>
Reverse	<i>rE</i>

Stroke	4F
Stitch length	4L
Clamp	CL
Main thread tension	7F
Additional thread tension	8F
spare	d4

Press **S** to test.

8.6 Input Switches

Display C: status of Reverse switch

Display E: status of Safety Switch

Display G: status of Knee Stroke Switch

8.7 Electronic Handwheel

Display B: Rotation

Display C: Press Switch

Display DEFG: Encoder

8.8 Speed Limit Device to stroke

Digital Type: four gears

- Display C shows gear, display E, G display the status of the two switches inside.

Analog Type: Stepless speed change

- Display D, E, F, G show the sample value of the potentiometer.
- Adjustment: press [P] to save two gear position, and press [S] to save six gear position.

8.9 AC voltage

Display the current AC input voltage

e.g: **9 220**, AC voltage 220v.

8.10 Bus voltage

Display the current bus input voltage

e.g: **A 310**, bus voltage 310v.

8.11 A phase current sampling reference

8.12 B phase current sampling reference

8.13 AD1 sample value

8.14 AD2 sample value

8.15 AD3 sample value

8.16 AD4 sample value

8.17 Main MCU Software Version

E.g: **H 7 100**, version 1.00

8.18 Software Release Date

E.g: **1 16 100 1**, released on October 1, 2016

8.19 Slave MCU Software Version

E.g: ,version1.00

9. Appendix

9.1 Machine ID

9.1.1

Press hold 『A+』 key and turn on the power to access to adjust the machine ID, seven-segment displays F,G will display the ID, change it

and press to save.

9.1.2 Table of maximum speeds

ID	Model	Unit(sti/min)
1		2500
4	TW1-898L14D2T5	3500
5	TW1-999L14D2T5	2800
6	TW1-899SL14D2T5	2500
7	TW1-899SL14D2T5L	2800
8	TW2-898L14D2T5	2800
9	TW2-999L14D2T5	2500

9.2 Seven-Segment Display Characters Compare Table

0	1	2	3	4	5	6	7	8	9
A	B	C	D	E	F	G	H	I	J
K	L	M	N	O	P	Q	R	S	T
U	V	W	X	Y	Z				

9.3 Connector diagram

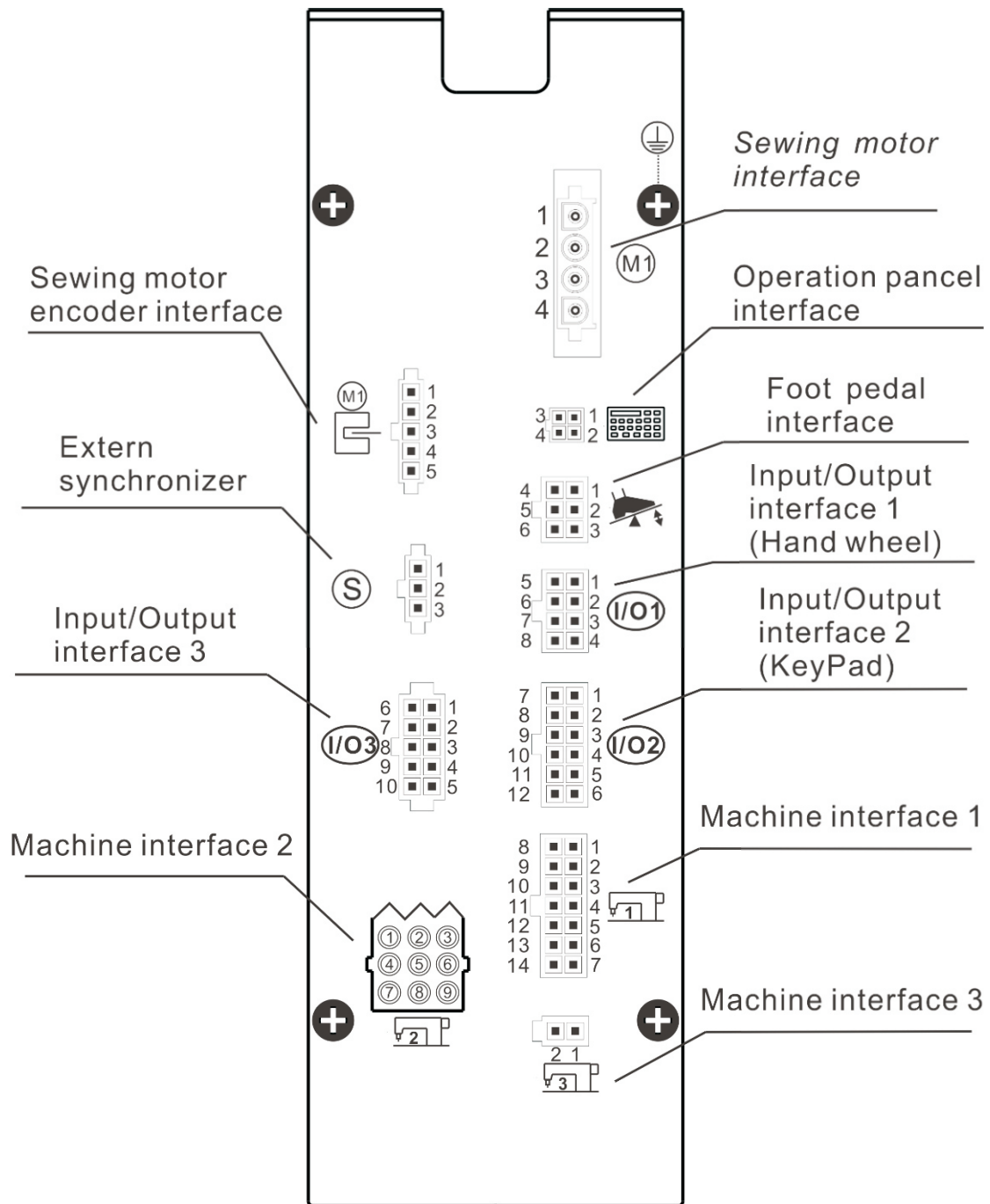

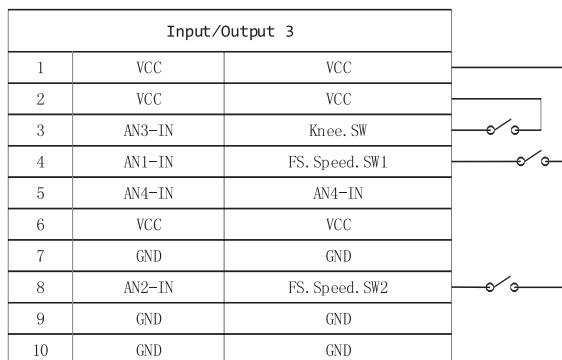
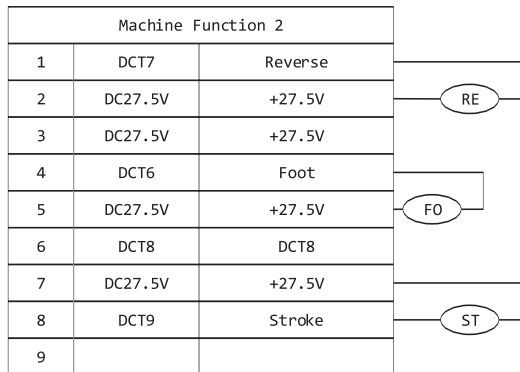
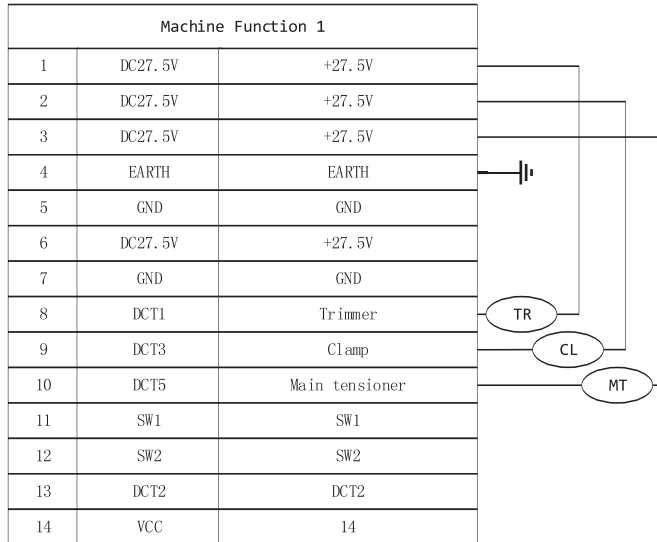

Encoder		Sewing motor	
1	DC-5V	1	EARTH
2	GNDS	2	A Phase
3	JT-UP	3	B Phase
4	MC-CHA	4	C Phase
5	MC-CHB		

Pance1		Foot Pedal	
1	VCC	1	IO3-IN
2	GND	2	IO6-IN
3	RXD21	3	IO2-IN
4	TXD21	4	Pedal
		5	GND
		6	VCC

Keypad		Synchronizer	
1	GND	1	VCC
2	GND	2	JT-UP-A
3	IO12-OUT	3	GND
4	IO11-OUT		
5	IO8-IN		
6	VCC		
7	IO1-IN		
8	IO5-IN		
9	IO4-IN		
10	IO9-IN		
11	IO10-OUT		
12	VCC		

Machine Function 3		Hand wheel	
1	DC27.5V	1	GND
2	DCT4	2	GND
		3	IO13-IN
		4	IO7-IN
		5	CHB-IN
		6	CHA-IN
		7	Z-IN
		8	VCC

Solenoid Abbreviations	
TR	Trimmer
MT	Main tensioner
AT	Additional tensioner
RE	Reverse
FO	Foot
SL	Stitch length
ST	Stroke
CL	Clamp

GC20665

DIRECT DRIVE 1 - AND 2-NEEDLE COMPOUND FEED
LOCKSTITCH SEWING MACHINE



This machine may only be operated by adequately trained operators only after having completely read and understood the instruction manual.

Parts are subject to changes in design without prior notice.



VETRON TYPICAL EUROPE GmbH

Clara-Immerwahr-Str. 6
67661 Kaiserslautern, Germany
Tel.: +49 6301 320 75-0
Fax: +49 6301 320 75-11

info@vetrontypical.com
www.vetrontypical.com